

SYQWEST INCORPORATED  
High Resolution Echo Sounders and Acoustic Systems  
for Precision Seafloor Exploration

# BATHY-500MF

## MULTI FREQUENCY- SURVEY ECHO SOUNDER

- INSTALLATION
- OPERATION
- MAINTENANCE

AVAILABLE  
WITH INTERNAL  
DGPS

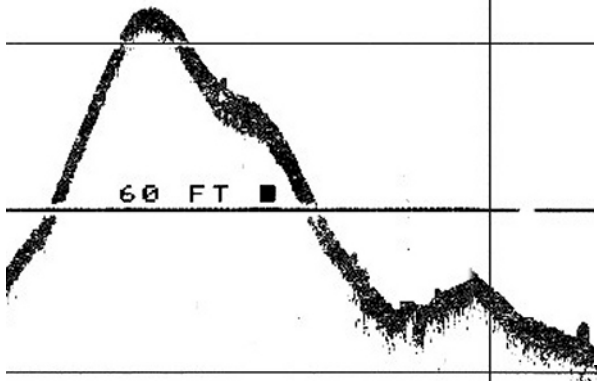
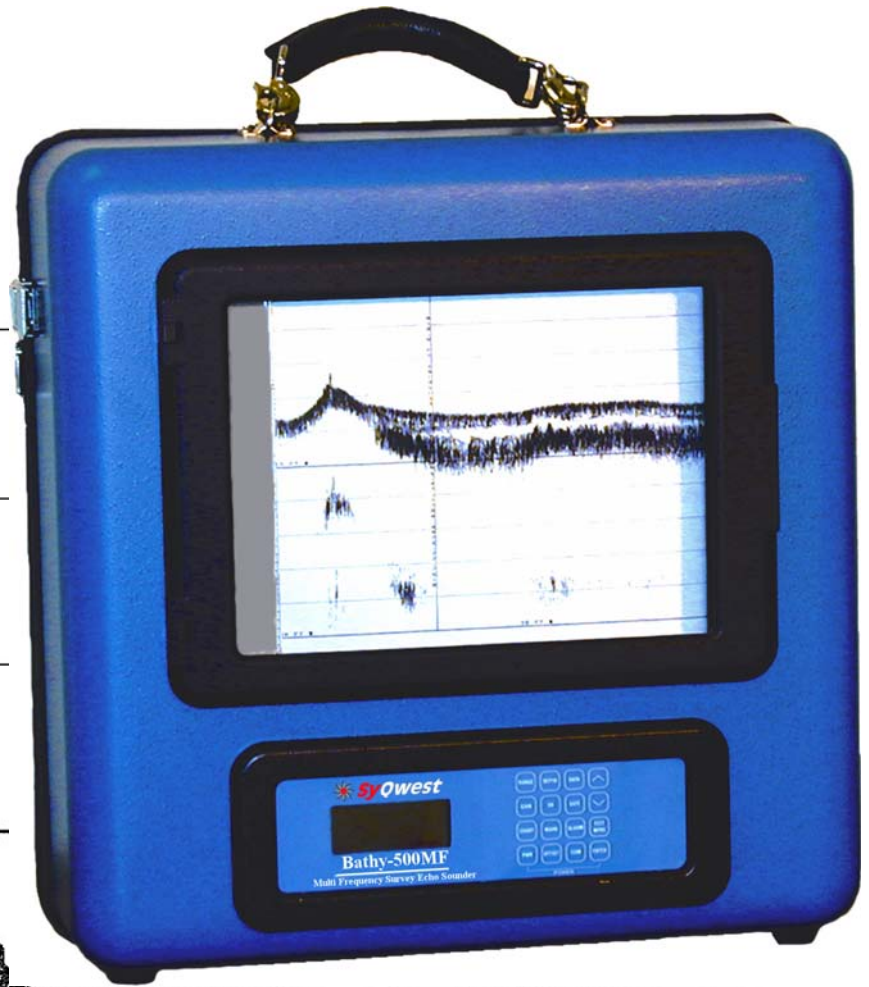

Ver 08.25.06a



222 Metro Center Blvd.\* Warwick, Rhode Island 02886

Tel: (401) 921-5170 \* FAX: (401) 921-5159

Website <http://www.syqwestinc.com/> Email: <mailto:tech-support@syqwestinc.com>



# TABLE OF CONTENTS

1.0	- INTRODUCTION .....	1-1
1.1	GENERAL INFORMATION .....	1-1
1.2	ECHO SOUNDING OVERVIEW .....	1-1
1.3	SPECIFICATIONS .....	1-2
2.0	- INSTALLATION .....	2-1
2.1	OVERVIEW .....	2-1
2.2	EQUIPMENT SUPPLIED .....	2-1
2.3	ACCESSORIES & OPTIONS .....	2-2
2.4	TRANSDUCERS (DIMENSIONS & MOUNTING) .....	2-2
2.5	Basic Connections .....	2-5
2.5.1	A.C. Power Input (& voltage selection) .....	2-5
2.5.2	D.C. Power Input .....	2-7
2.5.3	Transducer Plug .....	2-7
2.5.4	Fix Mark (remote) .....	2-7
2.6	DATA I/O INTERFACING .....	2-8
2.6.1	Connector Pin-out & Data I/O Set-up .....	2-8
2.6.2	RS-232 / RS-422 INTERFACE WIRING .....	2-9
2.6.3	Data Input .....	2-10
2.6.3.1	GPS Input .....	2-10
2.6.3.2	External Annotation Input .....	2-11
2.6.4	Data Outputs .....	2-11
2.6.4.1	ODOM dt Format .....	2-11
2.6.4.2	ODOM et Format .....	2-12
2.6.4.3	PMC dt Format .....	2-12
2.6.4.4	NMEA dbt .....	2-12
2.6.4.5	NMEA dbs Format .....	2-13
2.6.4.6	DESO-25 Format .....	2-13
2.6.4.7	ODEC dpt Format .....	2-13
2.7	CHART PAPER INSTALLATION .....	2-14
3.0	- OPERATION .....	3-1
3.1	THE KEYPAD .....	3-1
3.2	ON/OFF .....	3-1
3.3	KEY FUNCTIONS .....	3-2
3.3.1	Frequency Selection .....	3-2
3.3.2	DATA Key .....	3-3
3.3.3	DEPTH Key .....	3-3
3.3.4	FEET/MTRS Key .....	3-3
3.3.5	RANGE Key .....	3-4
3.3.6	GAIN Key .....	3-5
3.3.7	SV Key (Speed of Sound) .....	3-5
3.3.8	GATE Key .....	3-6
3.3.9	CHART Key .....	3-7

SYQWEST INCORPORATED

<http://www.syqwestinc.com>

[tech-support@syqwestinc.com](mailto:tech-support@syqwestinc.com)

3.3.10	ALARM Key.....	3-8
3.3.11	MARK Key.....	3-8
3.3.12	OFFSET Key.....	3-10
3.3.13	COM Key.....	3-10
4.0	- MAINTENANCE .....	4-1
4.1	GENERAL.....	4-1
4.2	FUNCTIONAL OVERVIEW .....	4-1
4.2.1	Power Supply .....	4-1
4.2.2	Key/Display PCB .....	4-1
4.2.3	CPU PCB.....	4-1
4.2.4	Print/Drive PCB .....	4-3
4.2.5	T/R PCB (Transceiver).....	4-3
4.2.6	Data I/O PCB.....	4-3
4.3	DIAGNOSTIC CHART .....	4-3
4.4	CLEANING .....	4-4
4.4.1	Printhead Care .....	4-4
4.4.2	Printhead Roller.....	4-4
4.5	MECHANICAL REPLACEMENT PARTS .....	4-4
4.6	ELECTRICAL REPLACEMENT PARTS .....	4-8
4.7	SPARE PARTS.....	4-11
APPENDIX A.	- SPEED OF SOUND.....	1
APPENDIX B.	- SELF TEST FEATURE .....	1
APPENDIX C.	- LIST OF STORED PARAMETERS .....	1
APPENDIX D.	- OPERATION IN EXTREMELY SHALLOW WATER DEPTHS.....	1
APPENDIX E.	- SOFTWARE .....	1

**1.0 - INTRODUCTION**

---

**1.1 GENERAL INFORMATION**

The Bathy-500MF Survey Echo Sounder provides a high-contrast thermal chart record complete with alphanumeric annotation of important parameters such as geographic position, depth, speed of sound and offset for draft/tide. Real-time viewing of all parameters is provided to the user via front panel liquid-crystal display. Position input can be from either a standard C/A GPS receiver or differential GPS system. Depth data is available to external devices in digital form, via a versatile interface, whose format is selectable by the user using the front panel keypad. The user may obtain digital depth data output, in various industry standard RS-232/422 formats or NMEA-0183. The ability to accept external annotation input from various PC-based hydrographic software is standard in the Bathy-500MF.

Unit set-up and parameter changes are accomplished via the keypad. Important parameter values are retained by the unit in non-volatile memory when power is removed. A real-time internal clock provides time and date stamping of the chart record.

The Bathy-500MF is equally well suited for both applications which involve rapid depth of channel determination by viewing the chart record and for detailed hydrographic surveys whereby automatic operation and unattended logging of digital depth data is desired. The use of embedded parallel microprocessor architecture allows for operation of the chart recording function simultaneously with digital display and data outputs, while further having the real-time capability to implement a proven weighted bottom detection technique, adaptive bottom tracking gate and other advanced signal processing.

Entirely portable, the Bathy-500MF can be operated on any vessel of opportunity since a wide range of A.C. and D.C. input voltages can be used. Your Bathy-500MF is capable of operation on various frequencies as selected by the user; See Section 3.3.1 for frequency selection procedure. Space is provided in the rear of the unit to store the various transducer types. Since scale annotation is printed on the chart along with bottom features, only one type of chart paper is required; The user need not change paper type when changing measurement units from feet to meters or vice-versa.

**1.2 ECHO SOUNDING OVERVIEW**

Echo sounding measures water depth by measuring the time interval required for ultrasonic sound waves to travel, at a known velocity, from a known point (a vessel) to a reflecting surface (water bottom) and return. If the time is measured between the transmission of a sound wave and the reception of its echo, the depth may be determined by multiplying one-half of this time interval by the velocity of sound in the water column.

For accurate surveying, sound velocity (more correctly referred to as speed of sound since it is really a scalar value) must be determined and entered into the echo sounder. Sound speed in water is dependent upon the salinity, temperature and depth. For instruments that operate in shallow depths, as is the case for the Bathy-500MF, depth is not a major factor effecting sound speed, so such is not considered in this manual. Complete details regarding the various methods available to the user to measure or estimate sound speed is included in the chapter which describes unit operation (Section 3.0).

Under optimal desired survey conditions, only a single trace will be shown in the water column; That, of course, representing the water bottom. Various conditions do however exist which result in other marks between the zero line and obvious water bottom. Physical conditions such as a rapid temperature gradient (thermocline) or density variation (pycnocline) can form an acoustically reflective layer between the zero mark and true bottom. Further, dense biological material (plankton) may have the same effect While the user may, in many cases, easily recognize these layers (as represented on the paper chart), automatic digital depth tracking, display and output may be effected. In such cases, a blanking feature (manual gate feature on the Bathy-500MF) is required for robust, reliable unattended surveying.

**1.3 SPECIFICATIONS**

Depth Ranges:	Units of 0-15, 0 - 30, 0 - 60, 0 - 120, 0 - 240, 0 - 480, 0-1920 Feet or 0-5, 0 - 10, 0 - 20, 0 - 40, 0 - 80, 0 - 160, 0-640 Meters
Phasing	0-120, 60-180, 120-140, 180-300, 240-360, 300-420, 360- 480 through 1800-1920 Feet, Auto or 0-40, 20-60, 40-80, 60-100, 80-120, 100-140, 120-160 through 560-640 Meters, Auto
Chart Record:	8.5 inch X 90 Feet (21.59cm x 27.43mt) High-Contrast Thermal Paper
Digital Display:	LCD (4 lines X 16 characters) 0.25 inch (6.35mm) characters (Depth Display 0.75 inch (19.05mm) characters) (Backlighting: Electro-luminescent)
Depth alarms:	Shallow & Deep (selected by keypad)
Speed of Sound:	4600 - 5250 feet/second (1393 - 1590 meters/second) (user selected via keypad or default to 4800 feet/second)
Offset	0 to +30 feet or meters (allows the user, via keypad, to adjust for net sum of transducer depth and tide)
Geographic Position:	NMEA-0183 Format GGA or GLL Format from GPS/DGPS
Data I/O Compatability	COM 1 provides bi-directional interface to PC or other peripheral  device; This port accepts external annotation from external sources such as hydrographic software. This port also allows remote control of all echo sounder functions using SyQwest's Windows 95/98/NT based software.  COM 2 accepts GPS/DGPS inputs and provides additional ( from COM1) data outputs.
Data Output:	A) NMEA-0183 Format (GGA or GLL) B) RS-232/422 Depth (only) ODEC PMC dt (true depth & status) Atlas DESO 25 ODOM Digitrace ODOM Echotrac NMEA dbt NMEA dbs
Acoustic Output	Any single frequency (user selectable & changeable via keypad) from these: 33kHz,40kHz,50kHz,200kHz (@600watts maximum)
<i>(specifications continued)</i>	
Input Power:	11-30 volts D.C. (1.5 amps @ 12 v. 0.5 amp @ 30 v.) or 115/230 volts A.C. 50/60 hertz (20 watts)
Dimensions (Recorder)	Height (including handle) 19 inches (48.26cm) Width 17.5 inches (44.45 cm) Depth 9 inches (22.86 cm)
Weight	36 lbs.(15.87 kg) (plus transducer)

**SYQWEST INCORPORATED**

<http://www.syqwestinc.com>

[tech-support@syqwestinc.com](mailto:tech-support@syqwestinc.com)

**2.0 - INSTALLATION**

**2.1 OVERVIEW**

Presented in this section are Bathy-500MF physical and electrical details needed to utilize the product in either portable or fixed (installed aboard a vessel) mode. The equipment group shown below must be supplemented with an optional SYQWEST transducer as listed in section 2.4 or SYQWEST approved equal.

**2.2 EQUIPMENT SUPPLIED**

<u>SYQWEST Part Number</u>	<u>Description</u>	<u>Qty.</u>
P01500	Bathy-500MF Multi Frequency Unit	1
P01182	D.C. Power Cable	1
P01183	A.C. Power Cable	1
P01044	Data I/O Plug Kit	1
P01184	D.C. Fuse (spare) 5 amp, 250 V., 3AG	3
P01185	A.C. Fuse (spare) 0.5 amp, 250v.	3
P01200	Chart Paper Roll Kit (with take up roll)	2
P01504MF	Manual, Operators	1

(See section 2.4 for optional transducers)

**2.3 ACCESSORIES & OPTIONS**

SYQWEST Part Number    Description

P03050	Integral DGPS Option
P01170	Handheld Remote Fix Mark Switch (with 15 ft. cable)

**2.4 TRANSDUCERS (DIMENSIONS & MOUNTING)**

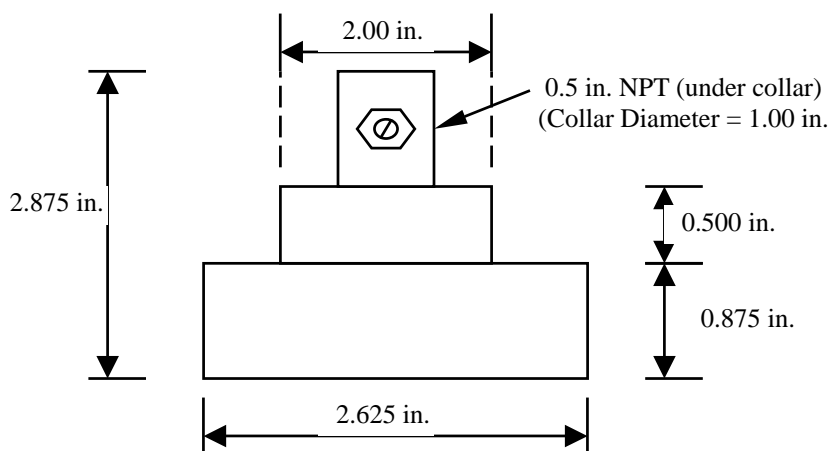

**P/N P01540 TRANSDUCER**



Resonant Frequency:	208 Khz.
Nominal Impedance:	50 ohms
Beamwidth (@ 3 dB point):	8 degrees
Cable:	30 feet (with plug to mate with recorder)
Housing Material:	Brass (with urethane acoustic window)
Piezo Material:	Barium Titanate



**P/N P01545 TRANSDUCER**

Resonant Frequency: 40 Khz.  
Nominal Impedance: 150 ohms  
Beamwidth (@ 3 dB point): 36 degrees  
Cable: 30 feet (with plug to mate with recorder)  
Housing Material: Brass (with urethane acoustic window)  
Piezo Material: Barium Titanate

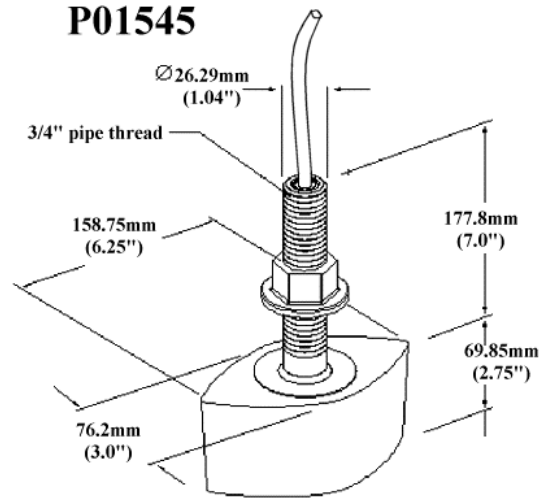

**P/N P02620 TRANSDUCER**

Resonant Frequency: 50 Khz.  
Nominal Impedance: 150 ohms  
Beamwidth (@ 3 dB point): 18 degrees  
Cable: 30 feet (with plug to mate with recorder)  
Housing Material: Brass (with urethane acoustic window)  
Piezo Material: Barium Titanate

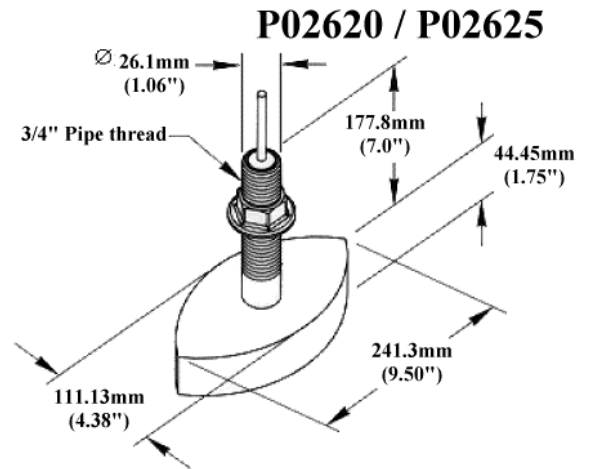

**P/N P02625 TRANSDUCER**

Resonant Frequency: 200 Khz & 50 Khz.  
Nominal Impedance: 150 ohms  
Beamwidth (@ 3 dB point): 9 degree & 14 degree  
Cable: 30 feet (with plugs to mate with recorder)  
Housing Material: Brass (with urethane acoustic window)  
Piezo Material: Barium Titanate



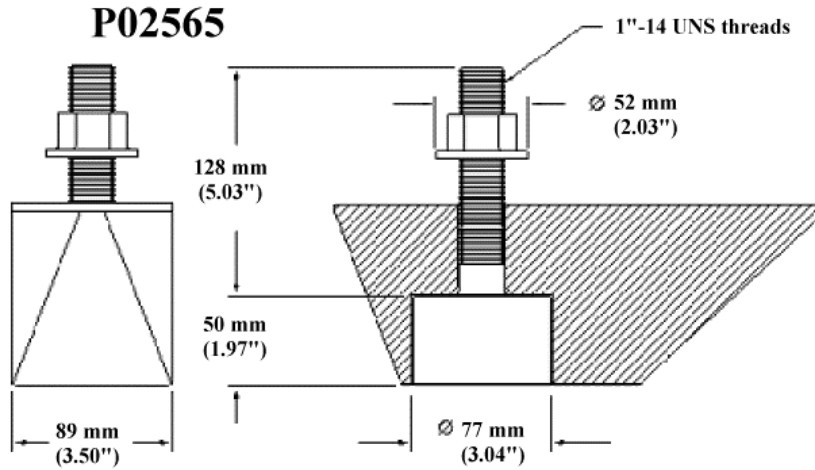

P/N P02565 TRANSDUCER

- Resonant Frequency: 200 Khz
- Nominal Impedance: 100 ohms
- Beamwidth (@ 3 dB point): 6 degree
- Cable: 30 feet (with plug to mate with recorder)
- Housing Material: Brass (with urethane acoustic window)

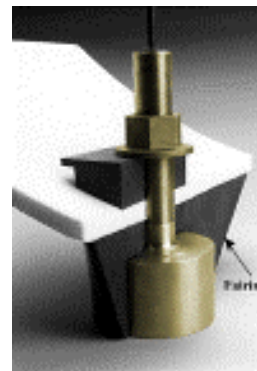

**P02560**

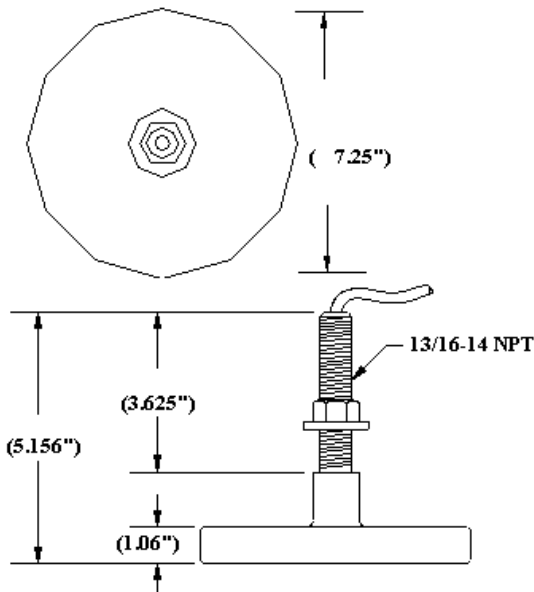

P/N P02560 TRANSDUCER

- Resonant Frequency: 210 Khz
- Nominal Impedance: 60 ohms
- Beamwidth (@ 3 dB point): 3 degree
- Cable: 30 feet (with plug to mate with recorder)
- Housing Material: Brass (with urethane acoustic window)
- Piezo Material: Barium Titanate



**2.5 Basic Connections**

All electrical connections to the Bathy-500MF are via quick-disconnect plugs, which attach to the rear of the center plate of the unit as shown below. Plugs are factory installed thus the user need not be concerned with details of the connector pin-outs unless field repair of cables or plugs is required; To aid in such cases, pin-out data is given in the following sections Information related to using the Data I/O connector port is given in section 2.6.

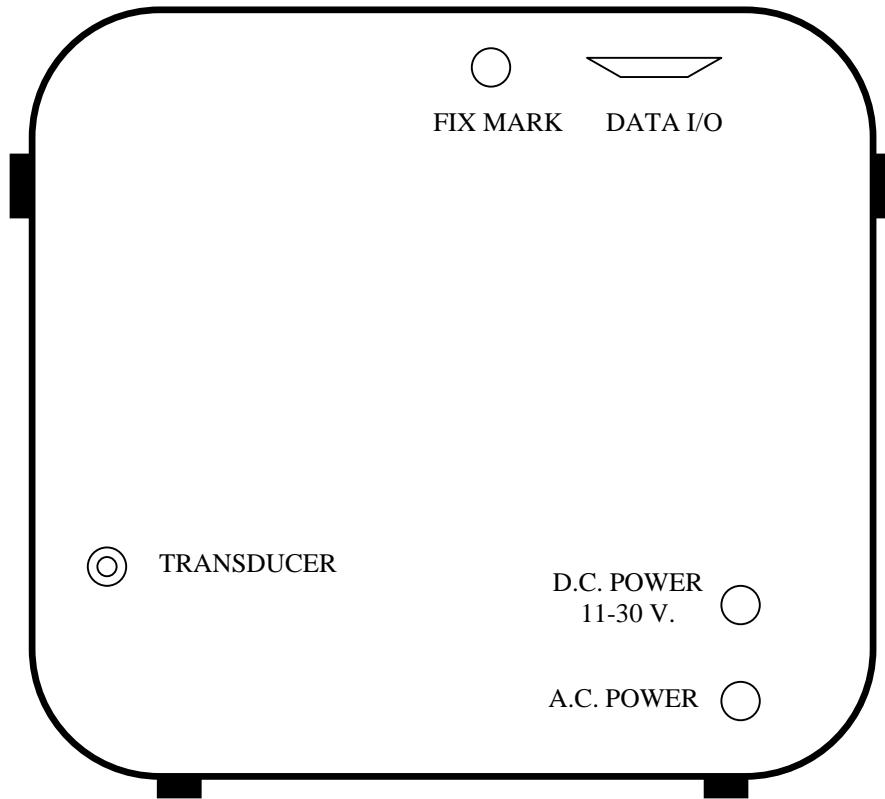

**2.5.1 A.C. Power Input (& voltage selection)**

Before applying A.C. power to the unit, the user must insure that the Bathy-500MF recorder has been properly configured with regard to A.C. voltage (115 or 230). Jumpers on the left side of the P/N P01080 Power Supply PCB must be reconfigured as shown below. For safety reasons the A.C. Power cable must not be placed into the center plate connector when jumpers are removed or installed. At all times that the protective plastic cover is removed from the unit the power cable should be unplugged.

**NOTE: Bathy-500MF units are shipped from the factory configured for 115 volts A.C.**

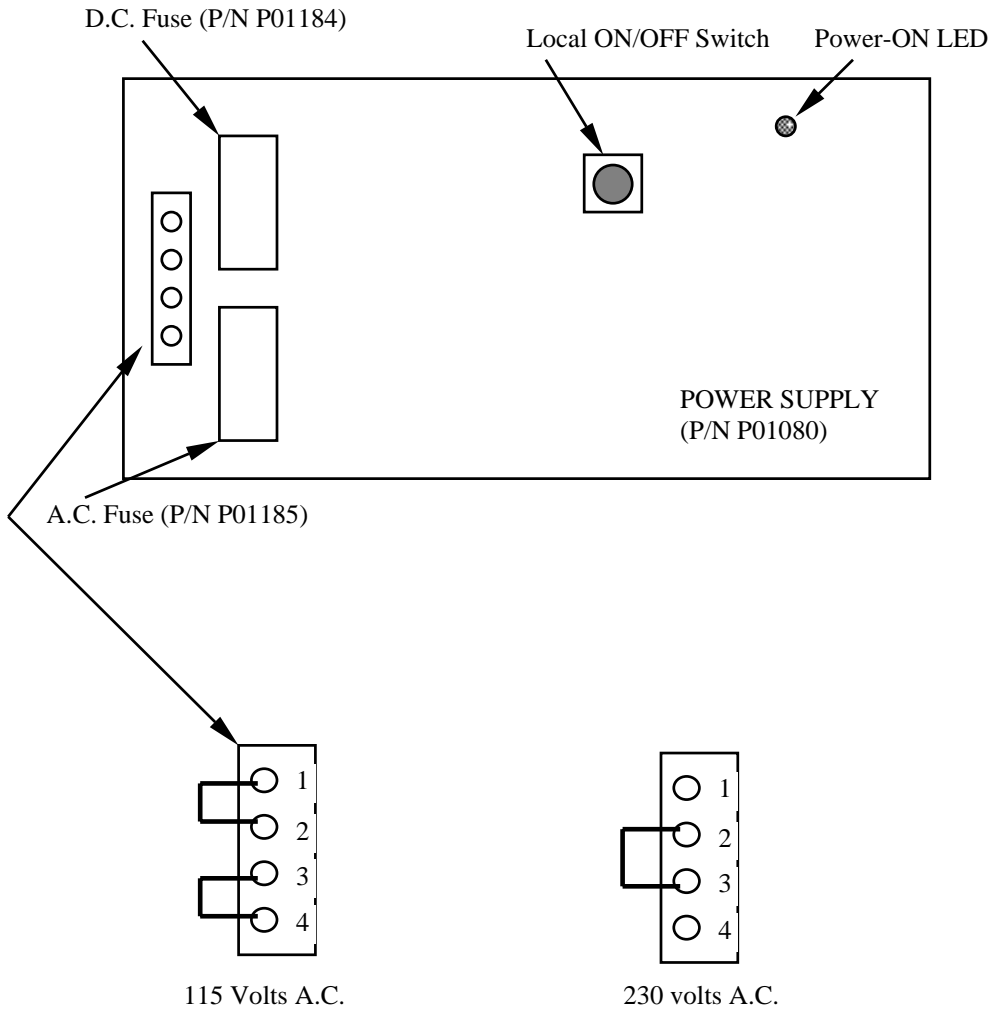

**JUMPER FORMAT FOR A.C. VOLTAGES**

Shown above, in addition to voltage setting information is the local ON/OFF switch and power ON LED. Details on these items are described in section 4.0 (maintenance).

Should it become necessary to add additional cable or to repair the P/N P01183 A.C. Power Cable, the user should refer to the plug diagram below.

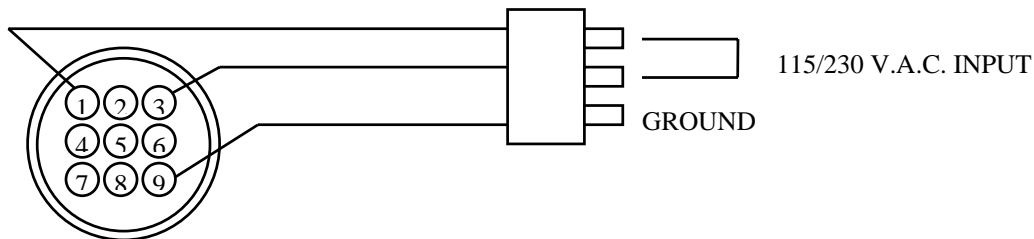

VIEW SHOWN IS PLUG FROM REAR (WIRE SIDE)

**2.5.2 D.C. Power Input**

If the user desires to operate the Bathy-500MF from a D.C. source any battery supply in the range of 11 to 30 volts may be used. No selection of the input voltage need be done as the power supply or the unit will regulate automatically over the stated voltage range. The user need only connect the P/N P01182 D.C. Power Cable Color-coded battery clips (red = positive +) are factory installed on this cable assembly. If cable replacement is required refer to the diagram below.

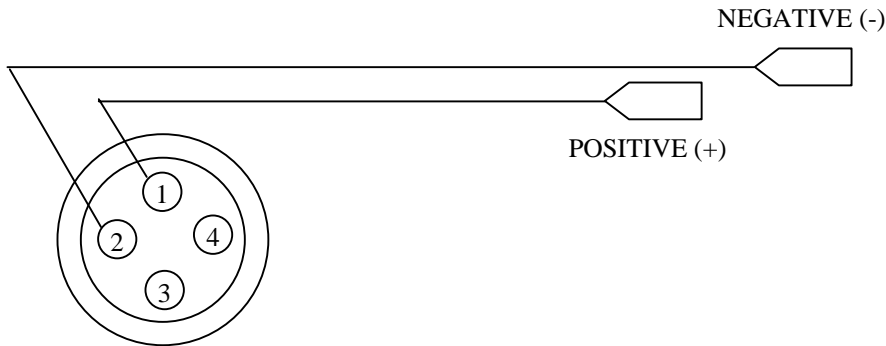

VIEW SHOWN IS PLUG FROM REAR (WIRE SIDE)

**2.5.3 Transducer Plug**

The transducer plug for the Bathy-500MF, as pre-wired from the factory, is shown below.

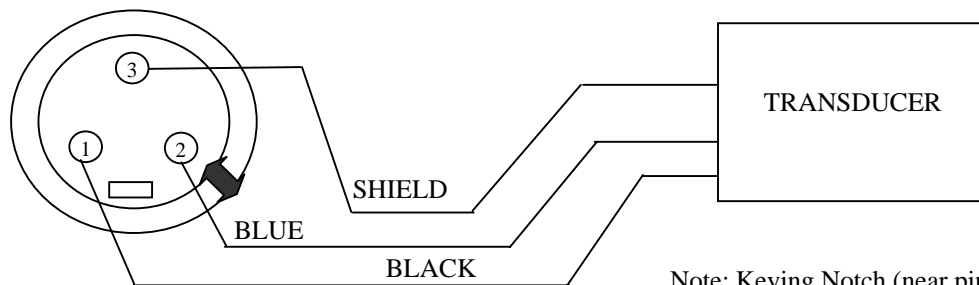

Note: Keying Notch (near pin 2)

VIEW SHOWN IS PLUG FROM REAR (WIRE SIDE)

**2.5.4 Fix Mark (remote)**

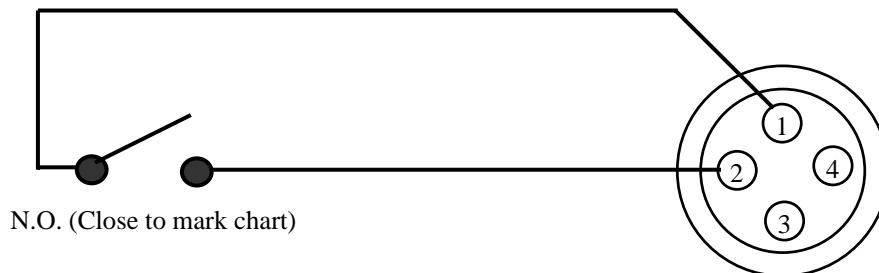

VIEW SHOWN IS PLUG FROM REAR (WIRE SIDE)

## 2.6 DATA I/O INTERFACING

Data input (geographic position or external annotation) and parameter outputs interface thru the Data I/O connector on the rear of the center plate. For this purpose, the P/N P01044 Data I/O Plug Kit is supplied as part of the basic equipment delivery. The following sub-sections provide the systems integrator with all data required to utilize the Bathy-500MF as an integral building block of his hydrographic survey system.

### 2.6.1 Connector Pin-out & Data I/O Set-up

The Data I/O port is accessed using an industry standard DB-25 plug which is provided as part of the basic Bathy-500MF delivery. Pin designations are shown below.

<u>PIN NUMBER</u>	<u>FUNCTION</u>
1	Chassis Ground
2	RS-232 TXD
3	RS-222 RXD
4	RS-232 RTS
5	RS-232 CTS
6	RS-232 DSR
7	Signal Ground
8	(unused)
9	RS-422 TXD +
10	RS-422 TXD -
11	RS-422 RXD+
12	RS-422 RXD
13	RS-422 RTS+
14	RS-422 RTS
15	RS-422 CTS+
16	RS-422 CTS
17	RS-422 DSR+
18	RS-422 DSR-
19	(unused)
20	RS-232 DTR
21	(unused)
22	(unused)
23	RS-422 DTR+
24	RS-422 DTR-
25	(unused)

Shown on the following page is an outline of the P/N P01090 Data I/O PCB. Jumper locations are shown for LK1 and LK2. If the user desires RS-232 output format, place a jumper block on LK-1. If RS-422 is desired, place the jumper block on LK-2  
**Note: Bathy-500MF units are shipped from the factory preset for RS-232. (Only one jumper block is to be installed at any time).**

2.6.2 RS-232 / RS-422 INTERFACE WIRING

SAMPLE WIRING CONFIGURATION FOR GPS AND OR DATA LOGGER

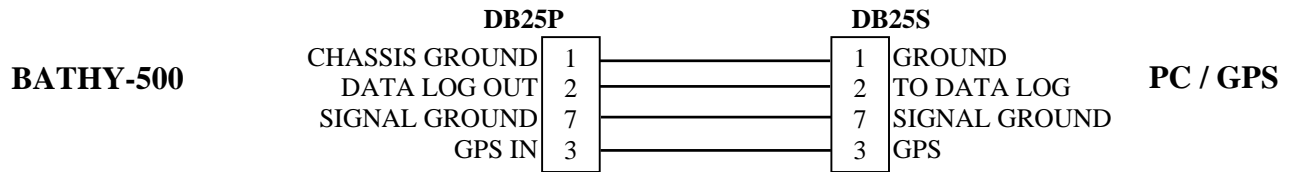

Figure 2-1 RS-232 DB25 TO DB25

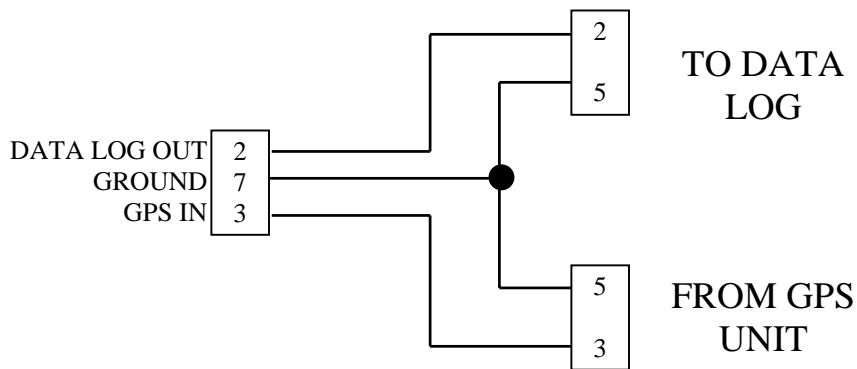

Figure 2-2 RS-232 DB25 TO DE9

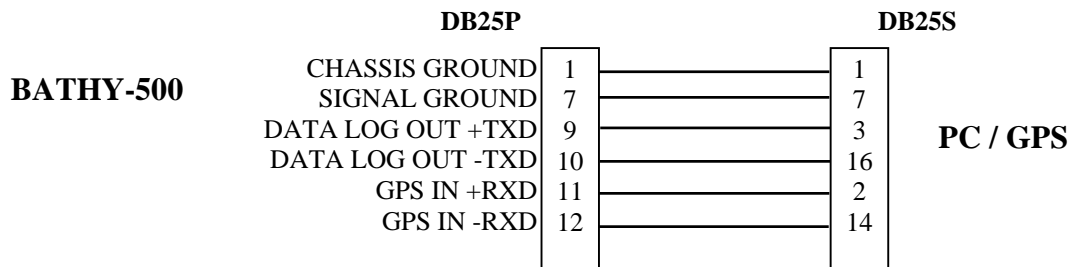
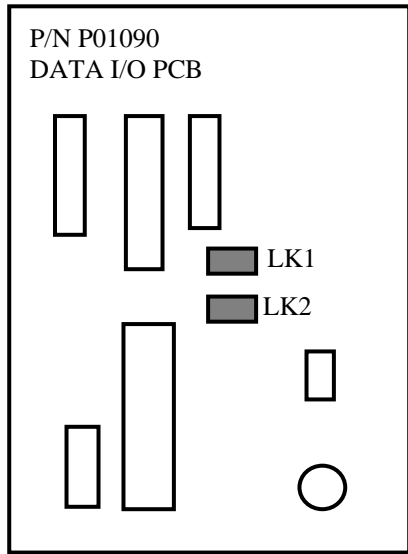

Figure 2-3 RS-422 DB25 TO DB25



RS-232/422 JUMPER LOCATIONS

**2.6.3 Data Input**

**2.6.3.1 GPS Input**

Your Bathy-500MF will accept NMEA 0183 input sentences containing GPS position in either GGA or GLL format. The unit auto detects when GGA is present in a sentence and accepts such as its first choice of position. Input position and unit time/date can be annotated on the chart record. The unit will accept input data in both RS-232 and RS-422 input levels as denoted in section 2.6.1

The standard NMEA 0183 data transmission format is as follows; Data is transmitted in serial asynchronous form in accordance with ANSI standards. The First bit is a start bit and is followed by data bits, least-significant-bit first as illustrated below. The following parameters are used: Baud rate = 4800/9600, Data bits = 8 (d7 = 0), Parity = None, Stop bits = One.

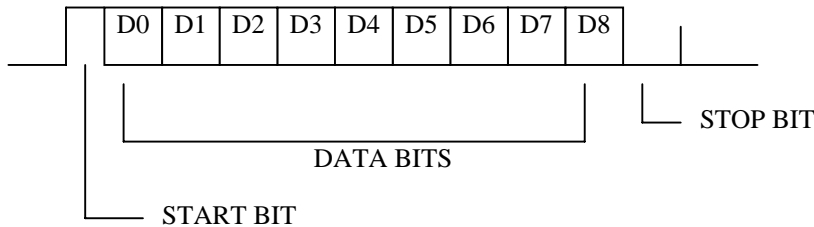



**2.6.3.2 External Annotation Input**

In lieu of GPS position your Bathy-500MF will accept external annotation from various PC-based hydrographic software; Up to forty-four characters (Alphanumeric-uppercase) may be printed vertically. Serial input is made to the same hardware pins as is used for GPS input; See Section 2.6.1.

To start an annotation string, "CONTROL F" then "CONTROL A" is inputted; This is followed by up to forty-four characters, then "CONTROL D" to end the string. Simply put, the sequence is shown below.

(CNTRL F) (CNTRL A) (ANNOTATION) (CNTRL D)

Should the user not desire vertical annotation but instead desire a vertical fix mark line, only a (CNTRL F) need be sent from the PC.

**2.6.4 Data Outputs**

Section 2.6.4 lists the various data output formats available from the Data I/O at the Bathy-500MF. This section provides more detailed, information for each format (sentence) to allow the user to interface with external peripheral devices Hardware pin-out connections are listed in section 2.6.1.

**2.6.4.1 ODOM dt Format**

Your Bathy-500MF emulates the digital depth output of the ODOM Digitrace depth digitizer unit. To receive ODOM dt format data, the user will connect his external receiving device to PIN 2 (RS-232 signal output) and PIN 7 (signal ground) on the Data I/O connector (DB-25 connector). The ODOM standard output data string contains 11 characters as shown below; No parity is used and the sentence has 8 data bits and 1 stop bit.

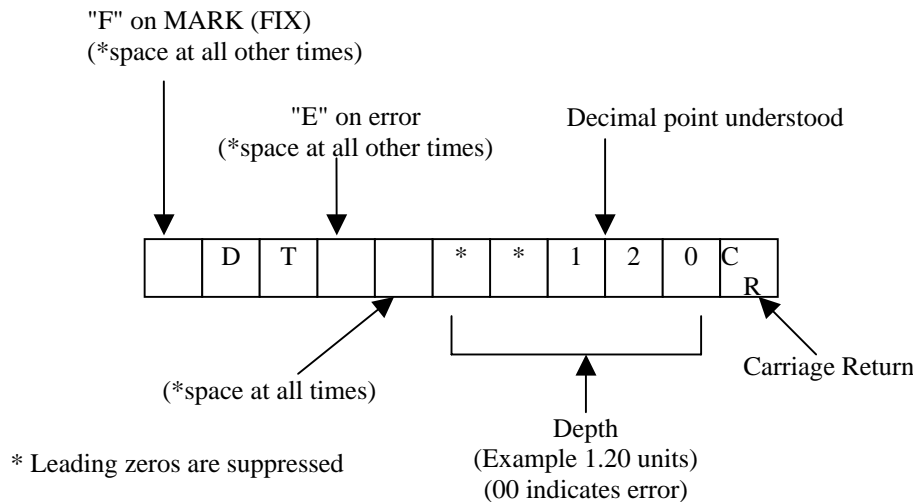

Byte 1:

An ASCII "F" (hex 46) appears as the first byte in the string whenever the operator depresses the recorder MARK key. The depth value in the output string reflects the depth at the point which the key is pressed. At all other times the ASCII "space" (hex 20) appears at this location.

Byte 2 & 3:

Characters 2 and 3 contain the unit identifiers. These are set to "D" and "T" (hex 44, 54).

Byte 4:

Position 4 is reserved as an error indicator in the form of an ASCII "E" (hex 45) and coincides with all zeros in the depth field. An ASCII "space" is present at all other times.

Byte 5:

This location will always contain the ASCII "space".

Byte 6 thru 10

True depth is given in these five positions with the decimal point understood to be fixed between bytes 8 and 9. Leading zero suppression is applied to the first two digits of depth. For example, for a depth of 8.5 feet, the five digits would appear as: space/space/8/5/0.

Depth in the output sentence will be corrected for Offset and Speed of Sound. In the event of an error due to loss of bottom tracking two zeros will appear in the depth field and the "E" character will occur in byte 4.

Byte 11:

A carriage return <CR> delimiter (hex )D) is always placed at the end at the string.

**2.6.4.2 ODOM et Format**

This output emulates the ODOM Echotrac output sentence as shown in the example below.

`_E T _ _ x x x x <CR>`

During normal operation the "space" in front of the "E" will be blank; When a Fix Mark is initiated, this space will contain the character "F". During proper equipment operation, the "space" immediately after the "T" is blank; Should the bottom be lost, an error condition s indicated by the character "E" being placed in this space.

Output in "FEET" units is denoted as "ET" while output in "METERS" is denoted as "et".

"1234" equals 123.4 feet). If in Metric mode, there would be two places after the decimal, thus "1234" equals 12.34 meters. Note that zeroes are suppressed.

**2.6.4.3 PMC dt Format**

The structure for this industry standard output is shown below.

`_D T _ _ x x x . x _FT <CRLF>` (English mode)

`_D T _ _ x x . x x _MT <CRLF>` (Metric mode)

During normal operation the "space" in front of the "D" will be blank; An "E" in this space indicates an error such as lost bottom while an "F" indicates a Fix Mark.

**2.6.4.4 NMEA dbt**

Data output will be NMEA 0183 depth below transducer sentence format as shown below.

`$ S D D B T , x x x . x , f , x x x . x x , M , x x . x , F <CRLF>`

Where `x x x . x` = feet (f)      `x x x . x x` = meters (M)      `x x . x` = fathoms (F)



2.7 CHART PAPER INSTALLATION

With your Bathy-500MF, two P/N P01200 Chart Paper Roll Kits are supplied. Additional kits are available from SyQwest Incorporated. *Do not use other paper types in your Bathy-500MF. Attempted use of other media will result in improper contrast shading and potential damage to the thin-film printhead. Do not attempt to substitute paper take up rolls as the roll furnished with the kit is designed (size and tolerance) to precisely fit the paper shaft. Use of any paper kit other than that type specified herein will void the thin-film thermal printhead warranty.*

Before beginning installation of a new paper roll, perform the following:

- 1) Remove the empty supply roll liner and full take up roll.
- 2) Clean debris from both paper shafts (under no circumstances add lubricants to shafts).
- 3) Place your print head lift arm in the UP position (as shown in the diagram below).
- 4) Use a dry cloth to clean any debris from the surface of the paper sensor (see below).

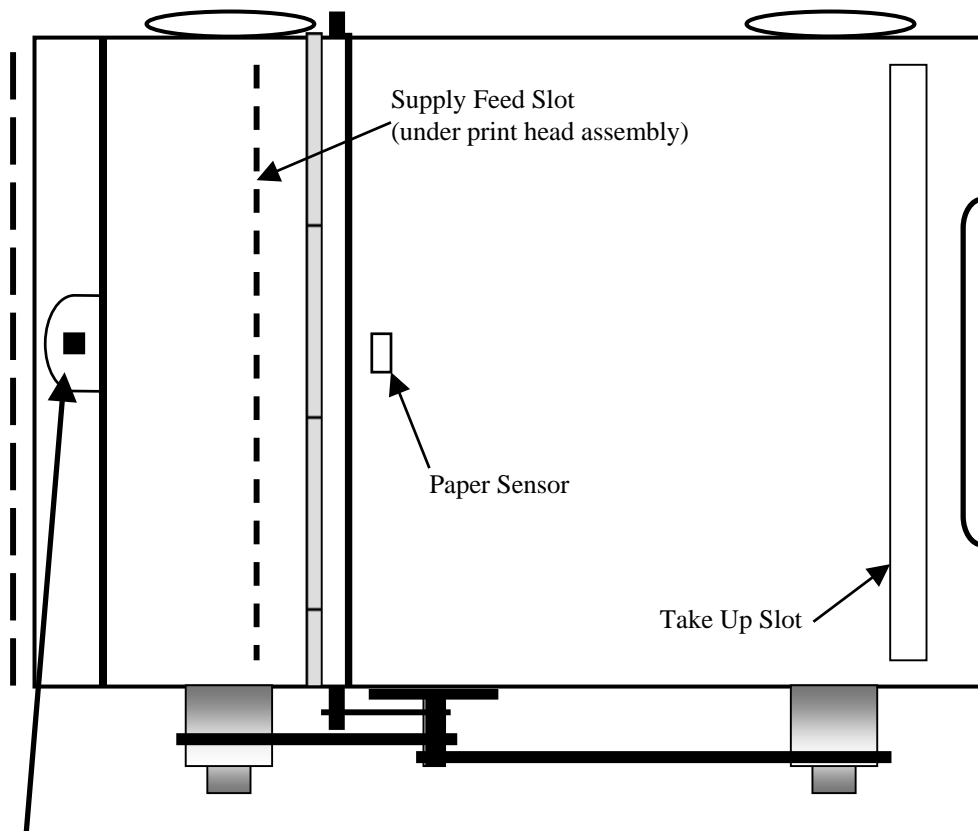

Print Head Lift Arm (UP position)

(continuing the paper installation process)

- 5) Install the new paper take up roll onto the take up paper shaft as shown below.
- 6) Install the new supply roll onto the supply paper shaft and feed the leading edge of the paper over the printhead roller, under the printhead assembly, across the chart module and down to the return slot and to the take up roll.
- 7) Use the take up clutch spool to adequate paper (for holding) onto the take up roll and to pull the paper taut across the chart module face.
- 8) Return the printhead lift arm to the down (closed) position (shown below).  
Insure that the paper is aligned with the platen bottom

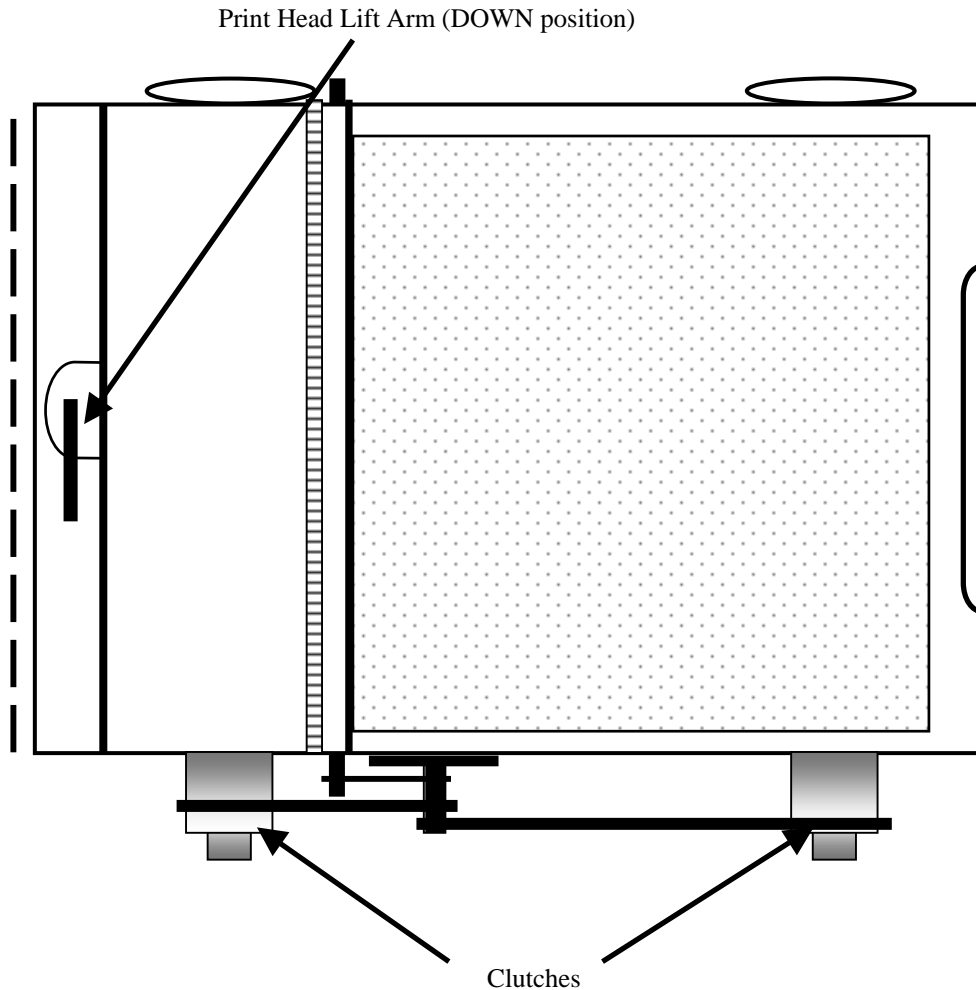
**SPECIAL NOTES:**

***Your Bathy-500MF contains an optical sensor (located in the platen just in front of the print-head) to halt printing should the paper supply become exhausted or if the paper is incorrectly aligned (buckled); Should the unit stop printing, power down, correct the problem then reapply power. Your Bathy-500MF will not power-up without proper paper supply alignment. Your Bathy-500MF also contains an automatic shutdown in the event of over-temperature; the unit will again function normally upon return to normal operating temperature range and reapplication of power.***

***Refer to Section 4.4.1 for the proper procedure to clean the printhead.***

**SYQWEST INCORPORATED**

<http://www.syqwestinc.com>

[tech-support@syqwestinc.com](mailto:tech-support@syqwestinc.com)

*THIS PAGE INTENTIONALLY LEFT BLANK*

3.0 - OPERATION

3.1 THE KEYPAD

Your Bathy-500MF is entirely controlled using the 16 keys which comprise the keypad as shown below.

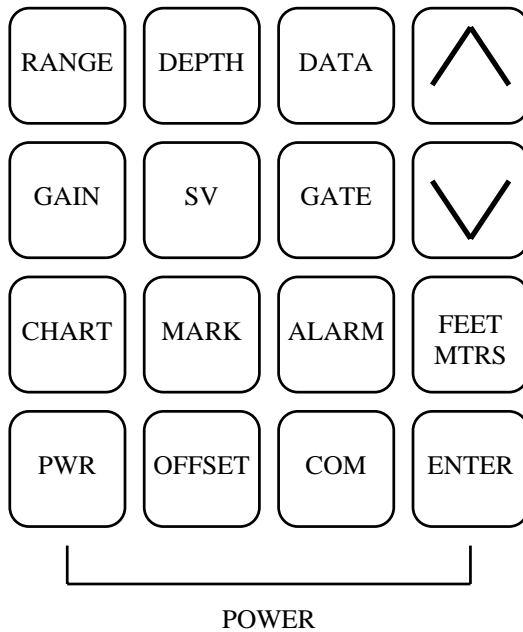
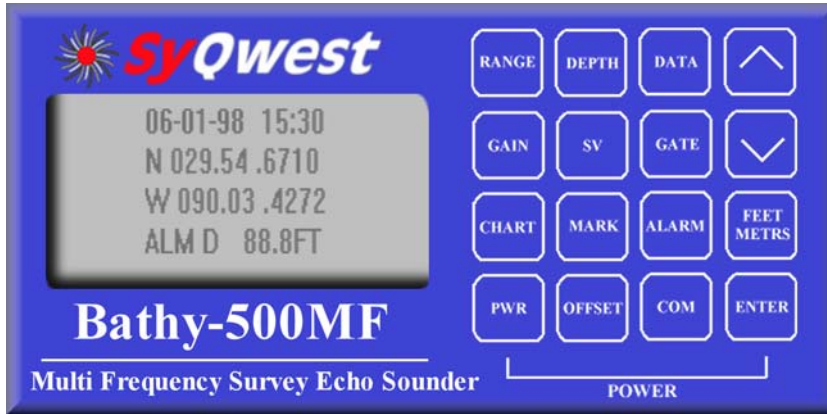

3.2 ON/OFF

Depressing the PWR and ENTER keys at the same time will turn on your Bathy-500MF: The same procedure is used to turn off the unit

Note: upon powering-down your Bathy-500MF, allow at least five seconds to elapse before powering-up the unit again; This allows time for orderly resetting of the system processor.

### 3.3 KEY FUNCTIONS

The following sections denote the detailed function of each key and show the associated display pages for each. No separate descriptive sections are given for the ON, ENTER or INCREMENT (up arrow) and DECREMENT (down arrow) keys; Their Functions are denoted in other sections.

#### 3.3.1 Frequency Selection

Upon powering up your Bathy-500MF, the LCD display will initially show the self-test page (See APPENDIX B ); Once this sequence is completed, the below shown page will appear for five seconds. A digital timer (line 3 of the below first page contains the timer status) counts down from 5.0 seconds to 0.0 seconds at which time the "DATA" (status) page is displayed. If, however, during the five second count-down, the "COM" key is depressed, the "SET FREQ" menu will appear.

The second example below indicates that your Bathy-500MF has been user programmed for 200Khz operation. If you desire this frequency, simply depress "ENTER". If not, use the "UP" and "DOWN" arrows to toggle between the other available frequencies (i.e. 33, 40, 50); When the desired frequency is shown, depress "ENTER".

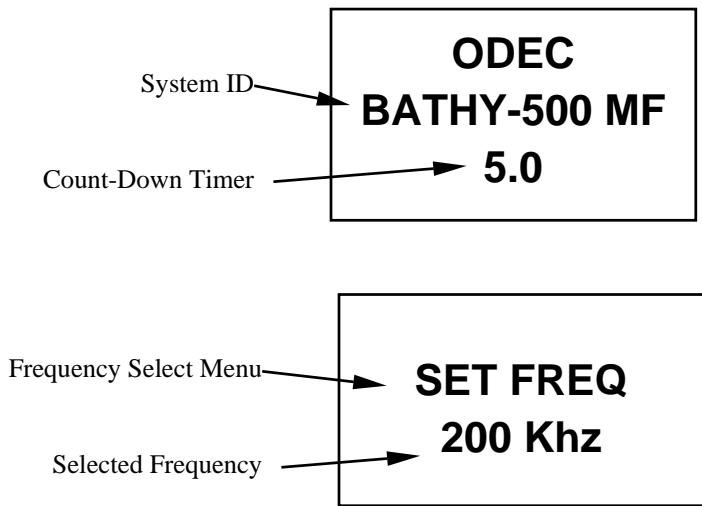

**WARNING: BEFORE CHANGING FREQUENCY, INSURE THAT YOU HAVE CHANGED THE TRANSDUCER AND T/R POWER LINKS (I.E. LK1, LK2, and LK3) TO PROPERLY OPERATE WITH THE NEW SELECTED FREQUENCY.**



**3.3.2 DATA Key**

Depressing the DATA key causes the status display page. as shown below, to be displayed.

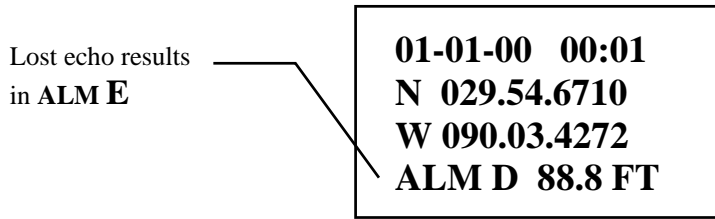

This display page, denoted status display, provides the user with a summary of the important parameters; Date, Time, Position, (if GPS data is present), Depth Alarm (if active) and Depth are shown

Depressing the DATA key a second Time calls up the second page for this key; This page allows the user to set the Time and Date. The second page (to the DATA key) is shown below.

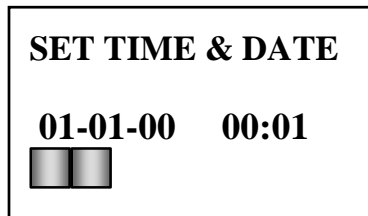

To set the month (if the double cursor is below the month designation), use the INCREMT and DECREMENT keys to change the month. To move from month to day (and then year), depress the DATA key as required; Each time using the INCREMENT and DECREMENT keys to change the value. Time is set in the same manner using the DATA key to move the cursor. To accept all values either depress the ENTER key or wait until the unit reverts to the status display page (this will occur after about ten seconds).

**3.3.3 DEPTH Key**

Depressing the DEPTH key will call up the large format depth screen page as shown below. This display, while being limited to the depth parameter only, provides for readability at extended distance from the unit. ( examples of English and Metric below)

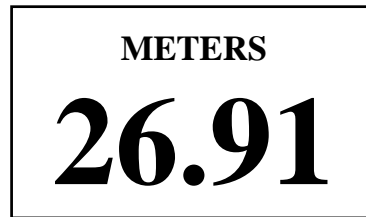
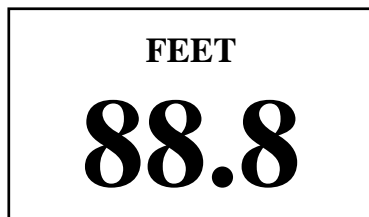

**3.3.4 FEET/MTRS Key**

Depressing this key toggles the chart presentation, digital display and data output between feet and meters.

**3.3.5 RANGE Key**

The user depresses the RANGE key once to view the range to which the unit is presently set. If the user desires to change the range, INCREMENT and DECREMENT keys are used to step thru the available depth ranges. Shown below is the range display for the maximum range (in feet).

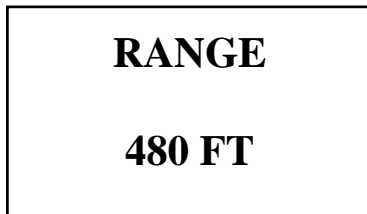

To accept new (after changing using the INCREMENT and DECREMENT keys), either depress ENTER or wait until the unit reverts to the previous screen.

Depressing the RANGE key a second time calls up the second page of this key, which is phase as shown below.

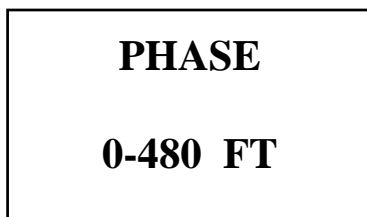

INCREMENT and DECREMENT keys are used to step thru the various phases; Selection of a new phase is either by depressing the ENTER key or waiting for the unit to revert to the previous page. A listing of the available ranges and phases are shown below.

Range Library:		Phase Library:	
0 - 30 FT.	0 - 10 METERS	P1 = 0-120 FT.	0 - 40 METERS
0 - 60	0 - 20	P2 = 60-180	20 - 80
0 - 120	0 - 40	P3 = 120-240	40-80
0 - 240	0 - 80	P4 = 180-300	60-100
0 - 480	0-160	P5 = 240 - 360	80 - 120
0-1920	0-640	P6 = 300 - 420	100 - 140
		P7 = 360 - 480	120 - 160
		thru 1800-1920	thru 560-640
		AUTO	AUTO

*For helpful hints when using you Bathy-500MF in extremely shallow water See Error! Reference source not found.*

**3.3.6 GAIN Key**

Depressing the GAIN key once will allow the user to view the previously set gain level. Using the INCREMFNT and DECREMENT keys, the user may then change the gain settings as desired and then accept such by depressing the ENTER key. INCREMENT and DECREMENT keys vary the gain in steps of 6db while the display (shown below) is linearized in bar-graph form. The numerical value shown to the right of the bar-graph represents the percent of total gain in use. Incrementing past one-hundred percent sets the unit in auto gain mode.

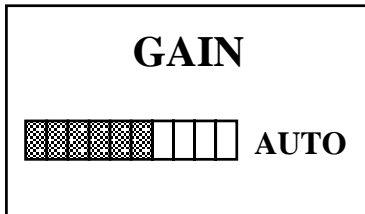

Depressing the GAIN key again will cause the previously set value for time-varied gain (TVG) to be displayed as shown below. TVG can be changed using the INRCEMENT and DECREMENT keys. Once ENTER is depressed the new values are accepted and the unit returns to the previous screen

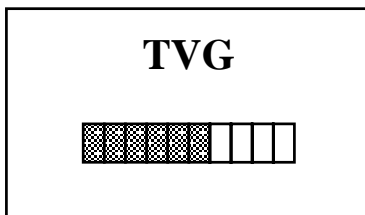

**3.3.7 SV Key (Speed of Sound)**

Depressing the SV key will call up the screen page as shown below. This display announces the currently used sound velocity (speed of sound); Display will be in either feet or meters depending upon which scale has been selected by the FEET/MTRS key.

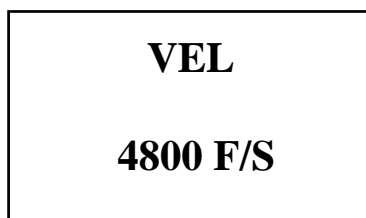

Once the above page is displayed, the user may change the sound velocity using the INCREMENT and DECREMENT keys; This value may be adjusted from 4600 to 5250 feet per second (1393 to 1590 meters per second). Once the desired value is displayed the user depresses ENTER or waits for the unit to revert to the previously viewed page.

The user may determine the sound velocity applicable to a specific survey using three methods:

A) Obtaining the measured sound velocity value from an external sound velocimeter.

B) Performing a "BAR-CHECK" using the Bathy-500MF. To accomplish such, a plate (bar) is placed at a known depth below the transducer face. The user then varies the speed of sound value until that exact depth is displayed on the DEPTH display page (and, of course, the chart). At that point of agreement the entered sound velocity value will be correct for the specific survey area and time. In effect, the Bathy-500MF contains an integral sound velocimeter.

C) By estimating the sound velocity considering the salinity and temperature of the given survey area and time. APPENDIX A provides a matrix of speed of sound values for various combinations of salinity and temperature.

**3.3.8 GATE Key**

Depressing the GATE key once allows the user to view whether the gate function is disabled (Off), designated to be automatic (Auto) or Manual Screen pages denoting the first two settings are shown below.



When the gate function is off, the first acoustic return (bottom or other) will be digitized and displayed as depth. In the automatic mode, a self-adaptive gate, based upon real-time mathematical modeling will be established. This mode provides the most robust digital bottom tracking. The user toggles between Off, Auto and Manual screens by pressing the GATE key.

The Manual mode is used when physical or biological conditions cause a "false bottom" in the water column. In such cases, the user may direct the Bathy-500MF to digitize acoustic returns only below that depth.

Once in the Manual mode, the user may change the false bottom blanking depth via the INCREMENT and DECREMENT keys. Depressing ENTER will then accept that value. An example of the Manual mode page is shown below.

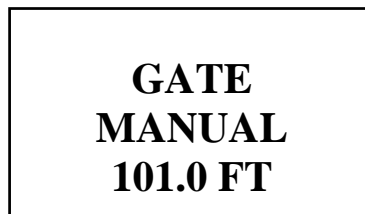

**3.3.9 CHART Key**

Depressing CHART key once will call up the first page of the chart key screens; This page, as shown below, denotes whether the Chart recorder (printing) is enabled or disabled. The user turns the chart printing on or off using the INCREMENT or DECREMENT keys.

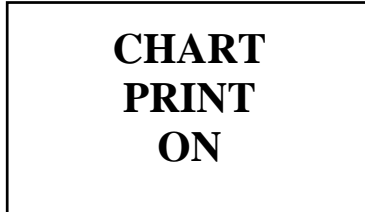

Depressing the CHART key twice moves to the second screen page of the chart key which denotes whether the chart speed is set to slow or fast. INCREMENT and DECREMENT keys toggle between these two speeds. The screen for slow speed is shown below.

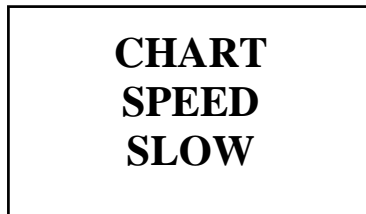

Depressing the CHART key again moves the display to the third screen as shown below; The user can toggle between chart lamp Off, Lo or Hi via the INCREMENT and DECREMENT keys. Lamp status OFF is shown below.

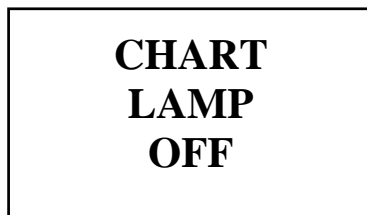

The fourth CHART key page is obtained by again depressing the CHART key. This allows the user to vary the print contrast of the thermal printer. A typical screen page denoting Lo contrast is shown below: Other settings are Med and Hi.



The fifth and final CHART key page is used to reset the paper gauge (% of paper remaining) when the user replaces the chart paper roll. To reset the gauge, the user depresses the INCREMENT or DECREMENT key to remove "No" from the CHART RESET page and replace such with "YES"; Then the ENTER key is pressed.

### 3.3.10 ALARM Key

Your Bathy-500MF allows the user to set an alarm for both shallow depth and deep depth limits. Upon either alarm condition, the audible alarm will sound and ALM S or ALM D will be shown on the status page (*see* DATA key display).

The user depresses the ALARM key once to view the first screen associated with this key. OFF is shown (as below), all alarms are disabled. To enable, the user presses the ALARM key again and moves on to set to shallow and deep alarm values as shown in further sections on this page.

**ALARM  
ON**

The user depresses the ALARM key twice to view the previously selected value for shallow depth. As with other parameters, INCREMENT and DECREMENT keys are used to change this value. A typical display for this screen page is shown below. Upon depressing the ALARM key a third time, the deep alarm limit is shown and can be changed in the same manner as the

**ALARM  
SHALLOW  
15.0 FT**

shallow alarm limit. A typical deep alarm screen page is shown below. Press ENTER to accept all values.

**ALARM  
DEEP  
225.0 FT**

### 3.3.11 MARK Key

Depressing the MARK key causes a vertical fix (event) line to be printed vertically across the chart; Holding down of this key (3 seconds or greater) will result in the printing of depth, position and other important parameters along the vertical line. The following page contains a sample chart record with such annotation; This vertical annotation is in addition to other annotation routinely printed on the chart record.

Chart Record Example

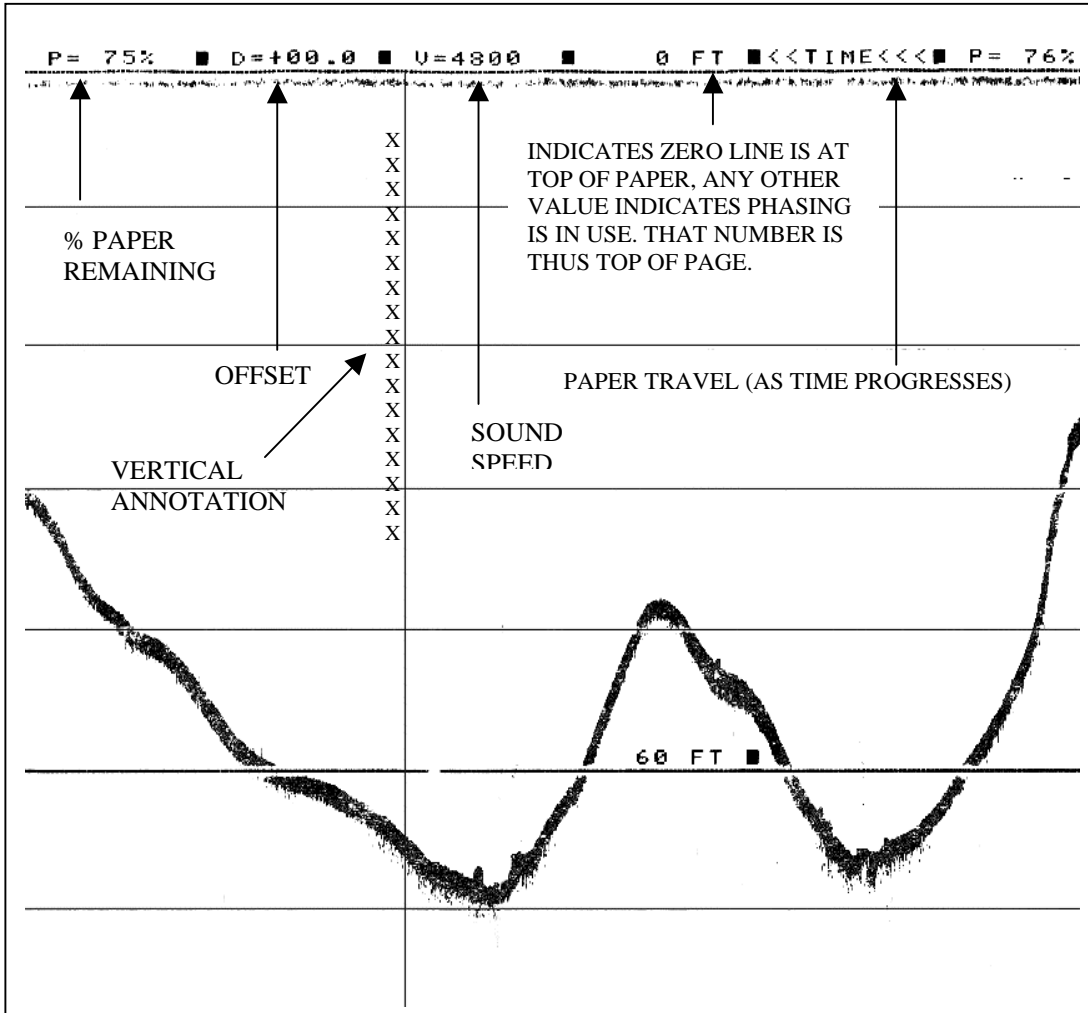

Note: in automatic gate mode, the actual bottom is shadowed (reduced line intensity) above and below to indicate the gate position and to verify bottom tracking was not lost.

**3.3.12 OFFSET Key**

This function allows the user to compensate for vessel draft tide etc or for difference in transducer depth and a historical waterline reference. The Offset value shall be the algebraic sum of all components that the user desires to include into a specific survey. A value, from 0 to +30 in tenths of feet may be entered via the INCREMENT and DECREMENT keys and then accepting such by depressing ENTER. Upon the user first depressing the OFFSET key, a screen page of the format shown below will be displayed



**3.3.13 COM Key**

Functions associated with the COM key (communications) allow the user to select various format digital outputs. Upon depressing the COM key, one of the below shown data output formats will be displayed; To change format, use the INCREMENT and DECREMENT keys to toggle between the five types shown; Then press ENTER to accept the output format desired.



Data output will be ODOM et (EchoTrac) format. Refer to section 2.6 for details of this format and other formats below.



Data output will be the ODOM dt (Digitrace) format.

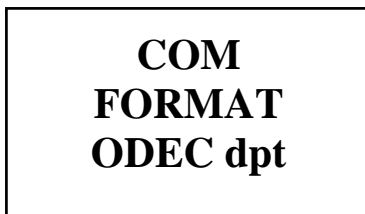

Data output will be the **ODEC dpt** format. (ODEC Proprietary string containing time, position, and depth)



**COM  
FORMAT  
PMC dt**

Data output will be PMC dt format

**COM  
FORMAT  
NMEA dbs**

Data output will be NMEA dbs (Depth Below Surface) format.

**COM  
FORMAT  
NMEA dbt**

Data output will be NMEA 0183 dbt (Depth Below Transducer) format.

**COM  
FORMAT  
DESO 25**

Data output will be DESO 25 (Atlas)) format.

Depressing the COM key a second time will result in the I/O BAUD menu page as shown below. The user may select either 4800 or 9600 via the INCREMENT and DECREMENT keys and then depressing the ENTER key. (Note that the baud rate of input data, if any, must match the baud rate of the output data selected).

**COM  
I/O BAUD  
9600**

*THIS PAGE INTENTIONALLY LEFT BLANK*

## 4.0 - MAINTENANCE

### 4.1 GENERAL

Your Bathy-500MF consists of individual functional modules as to provide for highest probability of field repair thus reducing survey downtime. No internal adjustments or calibration of the functional modules are required thus the recorder is serviceable by users without extensive knowledge of electronics or special test equipment. Section 4.7 provides a listing of all functional modules, hardware items, and cables which may be needed should your recorder ever fail.

### 4.2 FUNCTIONAL OVERVIEW

Eight printed circuit board assemblies (functional modules), along with the thermal printhead assembly and step motor, comprise the key sections of your Bathy-500MF recorder unit. A general technical overview of each printed circuit board containing active electronics follows:

#### 4.2.1 Power Supply

The Bathy-500MF power supply module functions to convert ac line voltage or low-voltage dc, power to regulated 24 volts D.C. to service all other functional modules. Other voltages (i.e. +5v D.C.) required by other modules is generated locally on each such assembly. The B.I.T.E. indicator (green LED) located on the power supply PCB verifies proper operation of this assembly, thus 24 volts D.C. is available to other modules.

#### 4.2.2 Key/Display PCB

The key/display printed circuit board serves to interface the CPU PCB to the liquid-crystal display and keypad. Keystrokes are converted to digital messages to be implemented by the CPU PCB, which collates bi-directional data from the other functional modules and communicates with the user thru the front panel display.

#### 4.2.3 CPU PCB

The central processor printed circuit board (CPU) provides the buss architecture for communication with other PCB's. This assembly houses software routines associated with the users operator interface. It contains both the real-time system clock which references all data to international time and date and it houses electrically erasable memory (EEPROM) which stores important parameters when the unit is turned off. A long-life Lithium battery is included to maintain the real-time clock function.

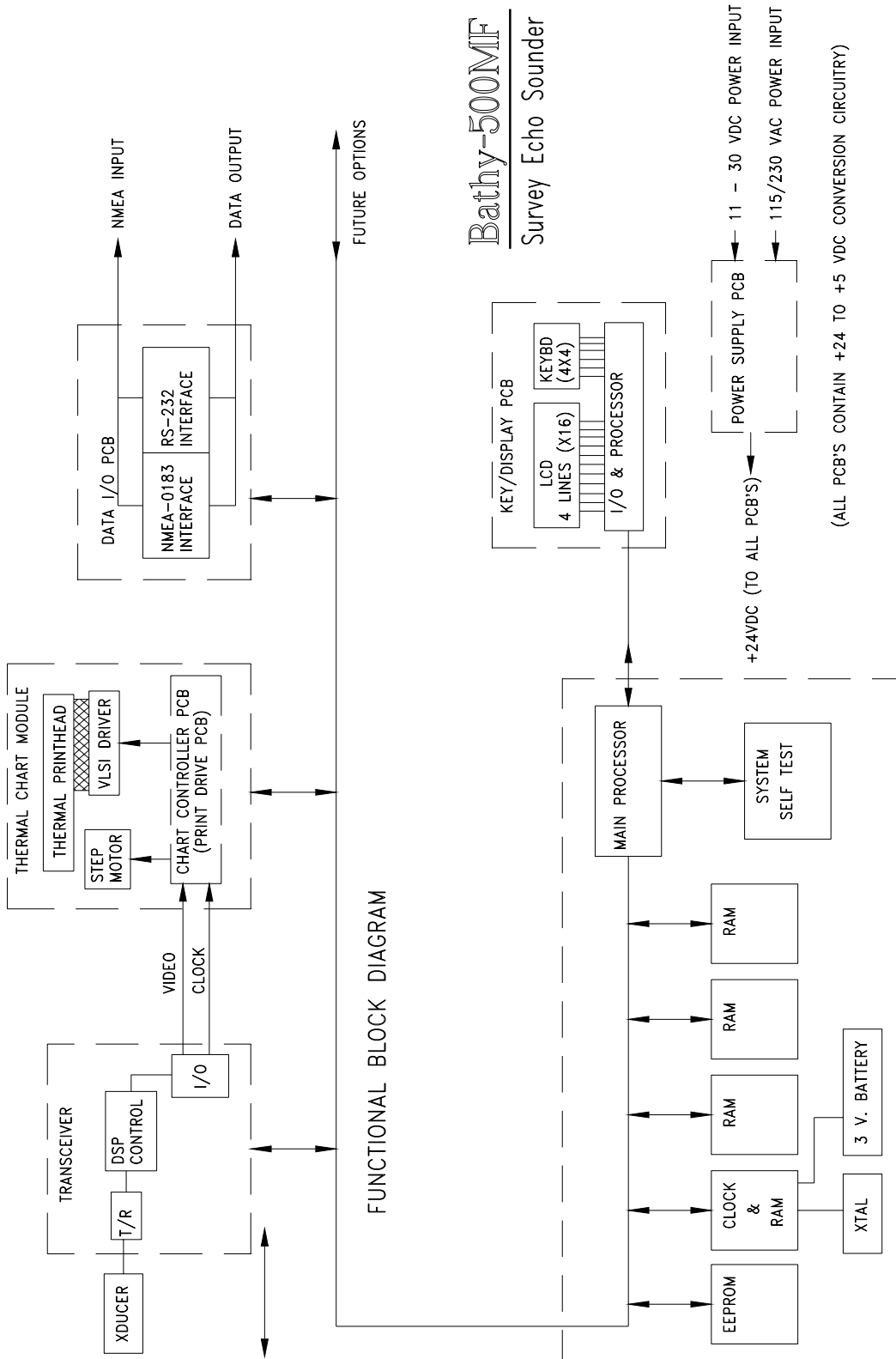

**4.2.4 Print/Drive PCB**

The print/drive PCB coordinates timing of the step motor which, in turn, controls the synchronous movement of the printhead roller and both paper shafts. At the same time water bottom data in digital form from the Broadband T/R PCB is converted into driver signals compatible with the thermal printhead. Further, in conjunction with a sub-assembly, the paper sensor, the print/drive PCB serves as a monitor of paper presence, stopping printing if the recorder is out of paper; Otherwise operation of the printhead without paper would damage the printhead.

**4.2.5 T/R PCB (Transceiver)**

Incorporating state-of-the-art digital signal processing the T/R PCB employs a trio of microprocessors, operating in parallel, to provide broad dynamic range and low noise operation. Both conventional gain and time-varied gain (TVG) capability is built into the T/R design; Each functional gain type is controlled via the keypad by the user (manually) or automatically (as enabled by the user). Digital control of transmit pulse form and frequency control provides for a robust acoustic source well suited for the operating depths of the Bathy-500MF.

**4.2.6 Data I/O PCB**

The Data I/O has two prime functions: 1) To accept geographical position data from a GPS receiver and; 2) To provide RS-232 or 422 digital depth data in industry standard format. The Data I/O contains a separate microprocessor (with local firmware) to format output data; Such architecture allows for future updates should data standards be revised.

**4.3 DIAGNOSTIC CHART**

*(SEE APPENDIX B FOR SELF-TEST FEATURES)*

SYMPTOM	CHECK & ACTION
Unit does not power-up	1) Check fuses; replace if defective. 2) Use Local On /Off switch on power supply PCB to attempt to power-up unit; If depressing this switch turns unit on, replace the key/display PCB; If not, replace the power supply PCB.
LCD functions; Chart does not	1) If the chart moves (but does not print) replace the printhead. 2) No chart movement Check to insure paper is covering paper sensor (without wrinkles); If so, and still no movement, go to step 3. 3) If the chart does not move, replace the print/drive PCB paper sensor PCB or step motor as applicable
No display or record of depth (other functions are normal)	1) Check transducer connections 2) Replace T/R PCB.
No GPS data or depth data output	1) Verify proper operation of external devices.
2) Replace Data I/O PCB	

4.4 CLEANING

4.4.1 Printhead Care

Your Bathy-500MF utilizes a long-life thin-film thermal printhead. While robust, care must be taken as to not allow sand and other such matter to come in contact with the printhead face. Should the interior of the case become contaminated with any such matter, stop operation at once; Raise the printhead assembly by using the lift arm, remove the paper and use dry air to remove all such particles from around the printhead and chart module paper travel surface. *Never clean the printhead surface with anything except a cotton swab, which has been moistened with Isopropyl alcohol. DO NOT USE ANY OTHER SOLVENT.*

4.4.2 Printhead Roller

It is important to maintain a clean printhead roller to prevent slippage during printing. *Before cleaning the printhead roller, always raise the printhead using the lift arm.* Use a cotton swab to clean the roller. If a solvent is needed, use only isopropyl alcohol. *Do not use any other solvent; the roller is synthetic rubber and will be damaged.*

4.5 MECHANICAL REPLACEMENT PARTS

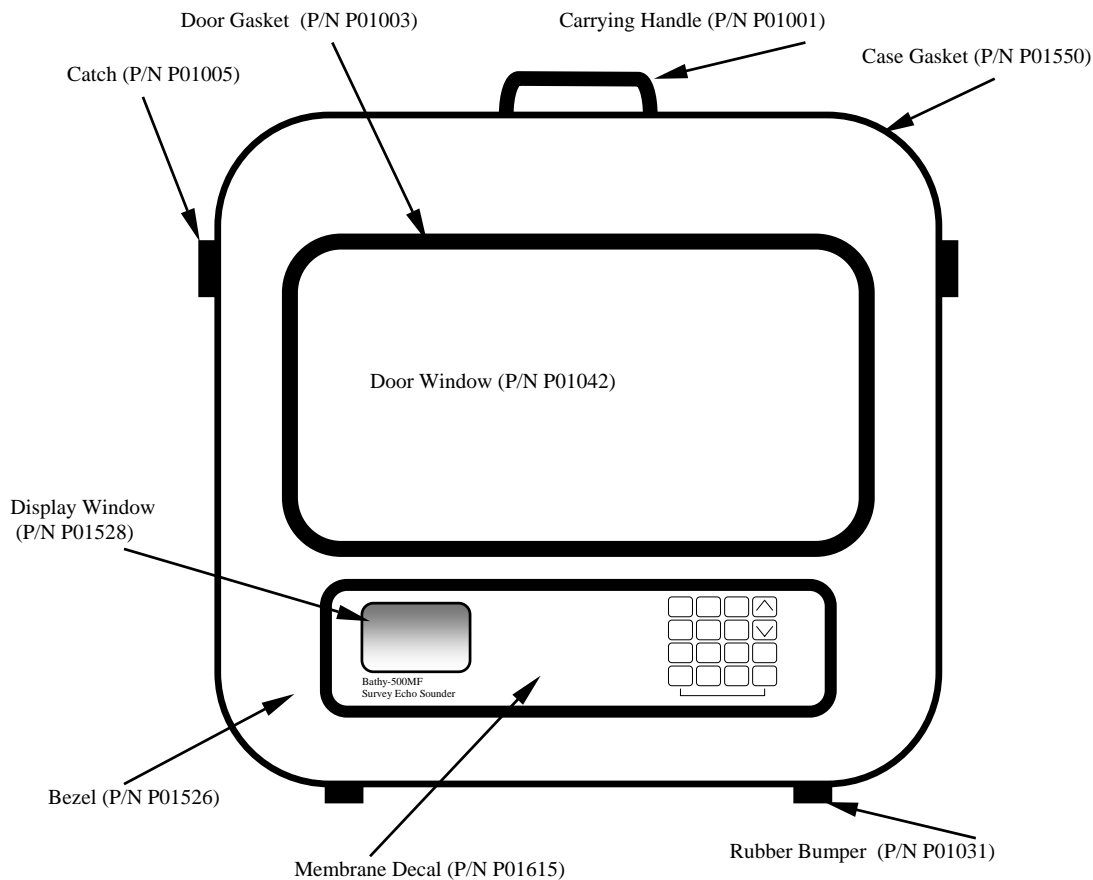

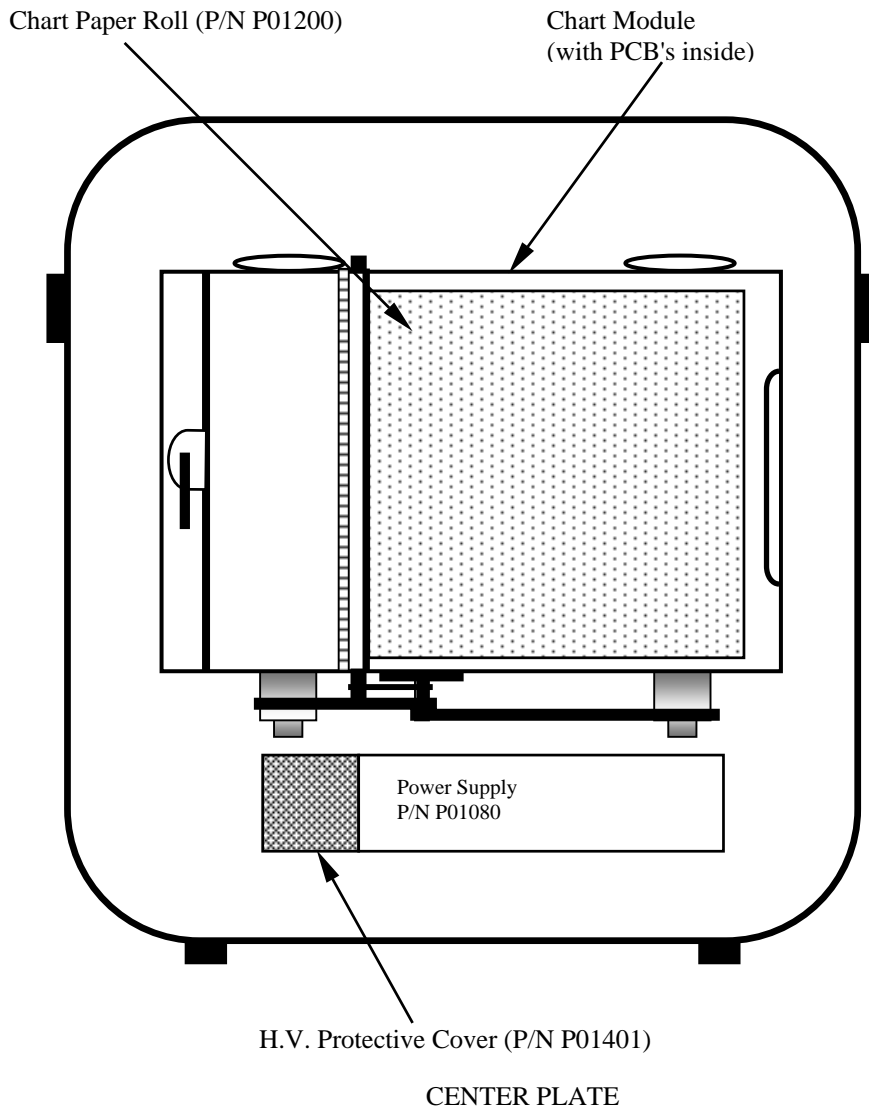

SYQWEST INCORPORATED

<http://www.syqwestinc.com>

[tech-support@syqwestinc.com](mailto:tech-support@syqwestinc.com)

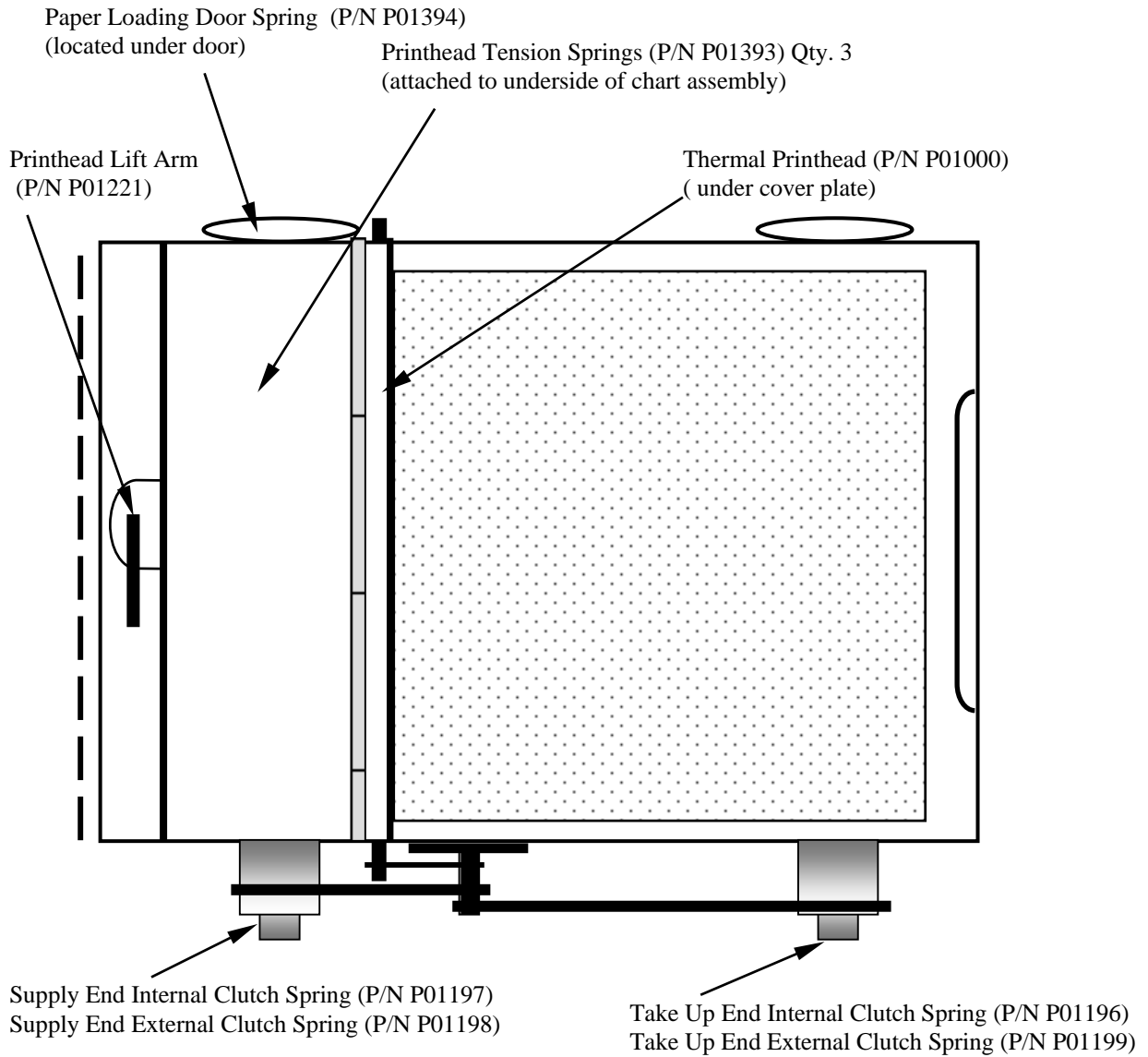

**CHART MODULE - EXTERIOR FRONT VIEW**



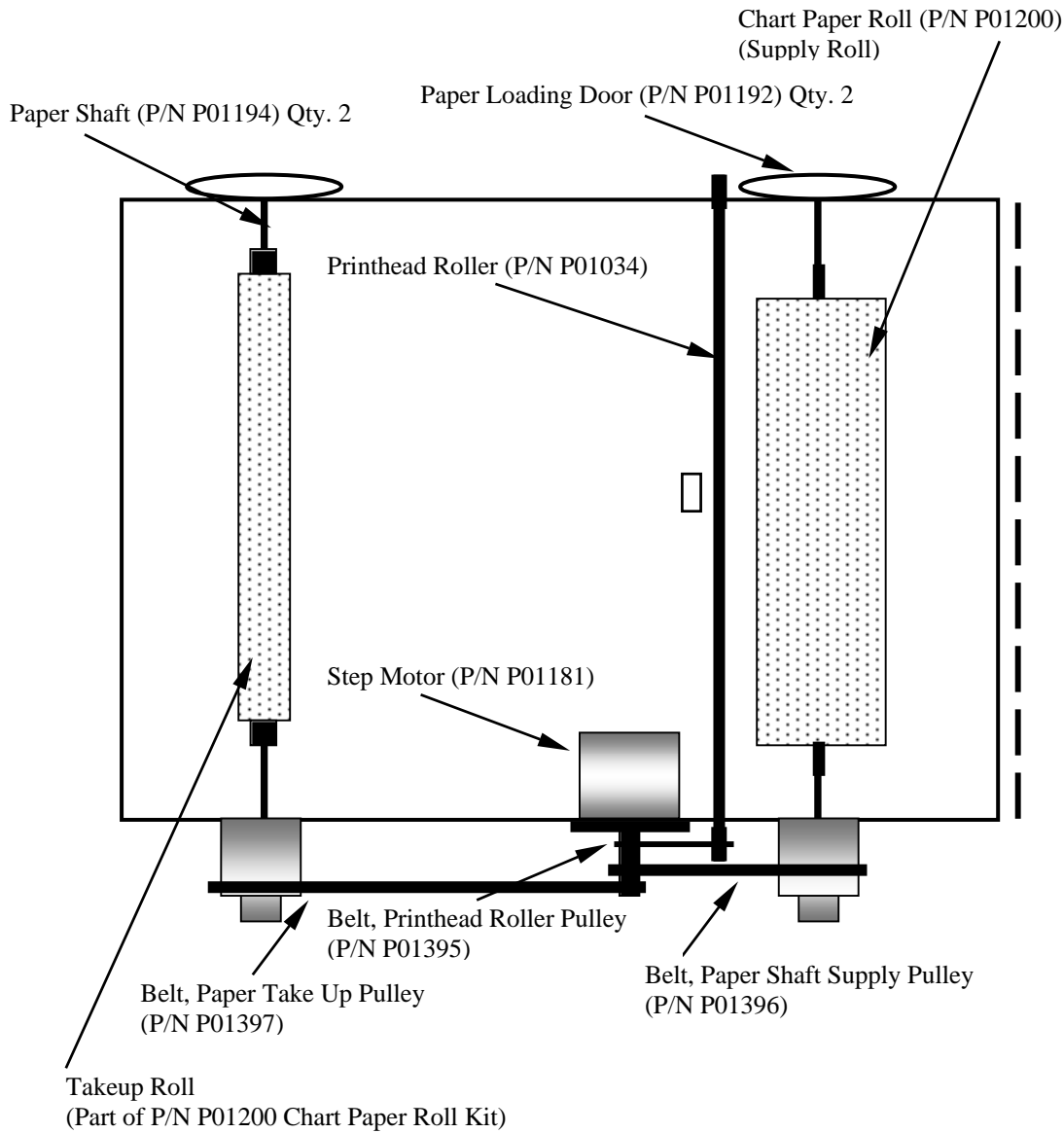

CHART MODULE - UNDERSIDE VIEW

4.6 ELECTRICAL REPLACEMENT PARTS

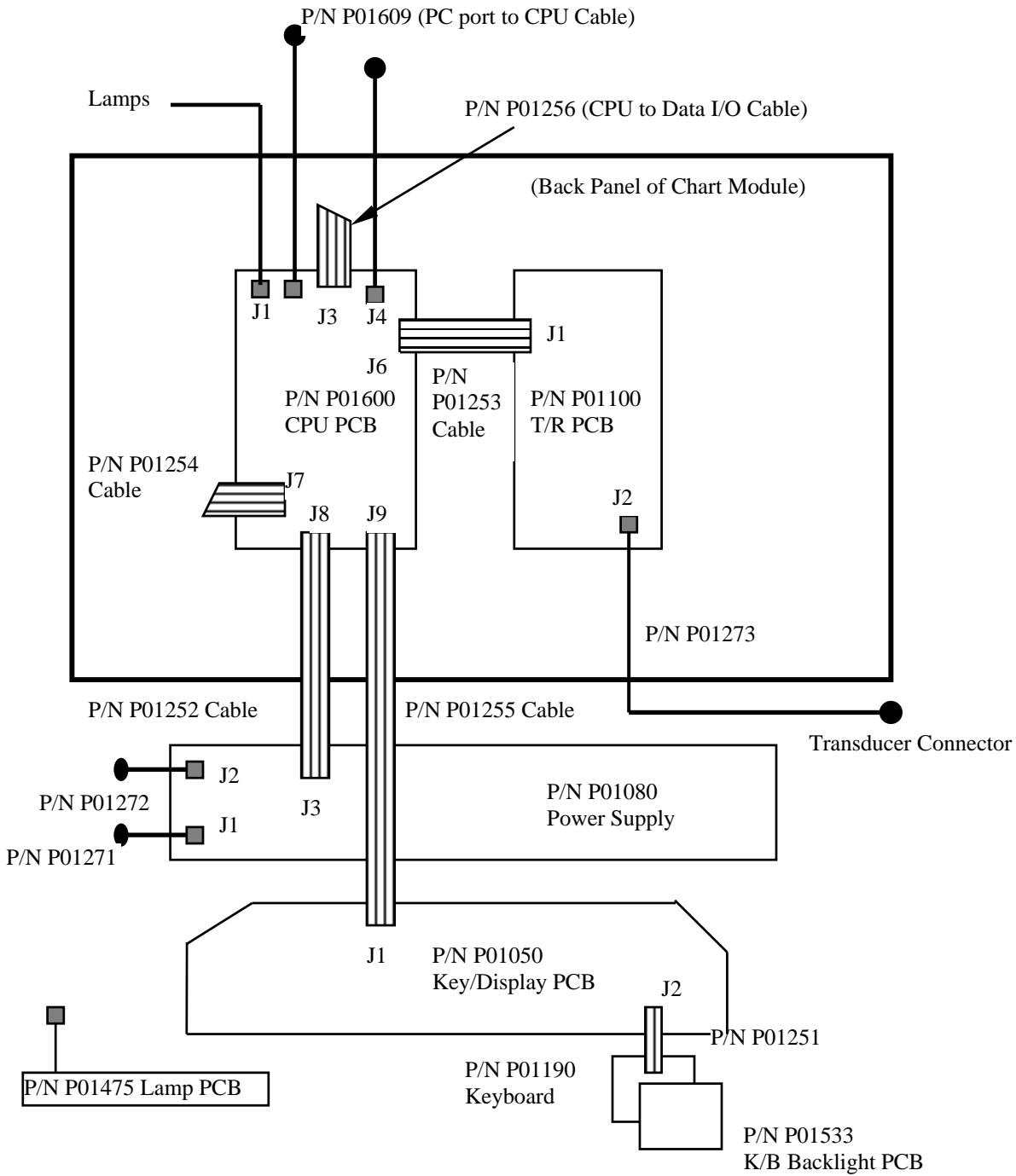

CHART MODULE REAR - CENT P/N P01274 Fix Mark to CPU Cable

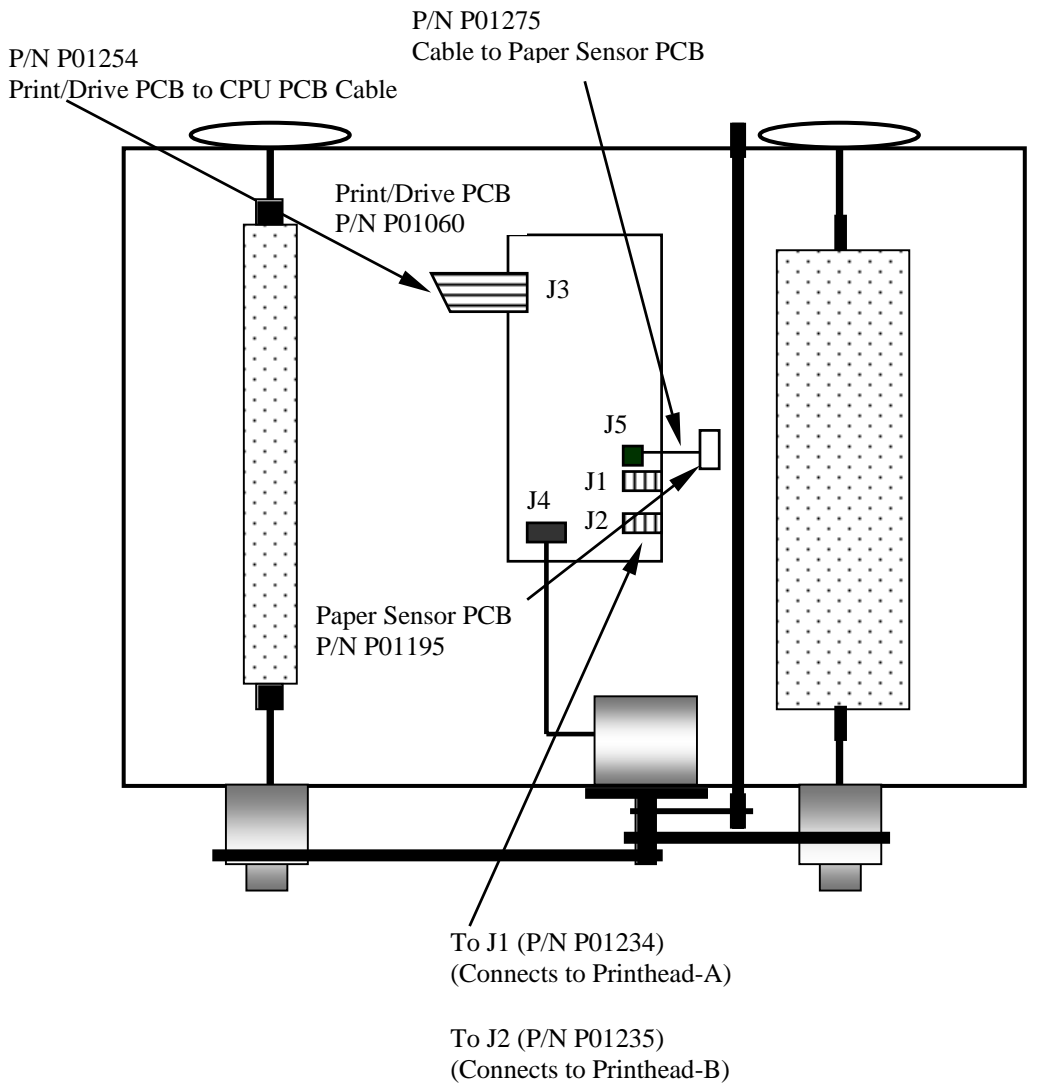
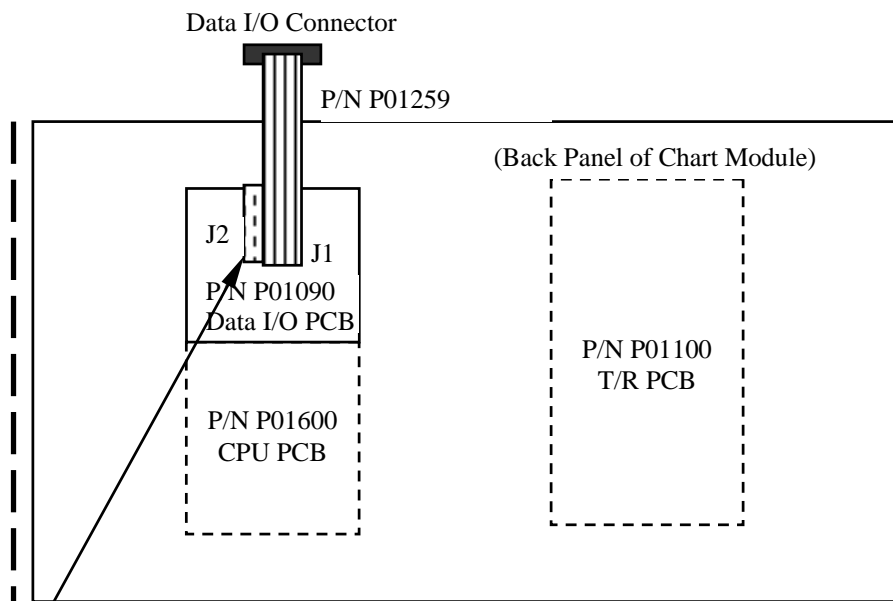
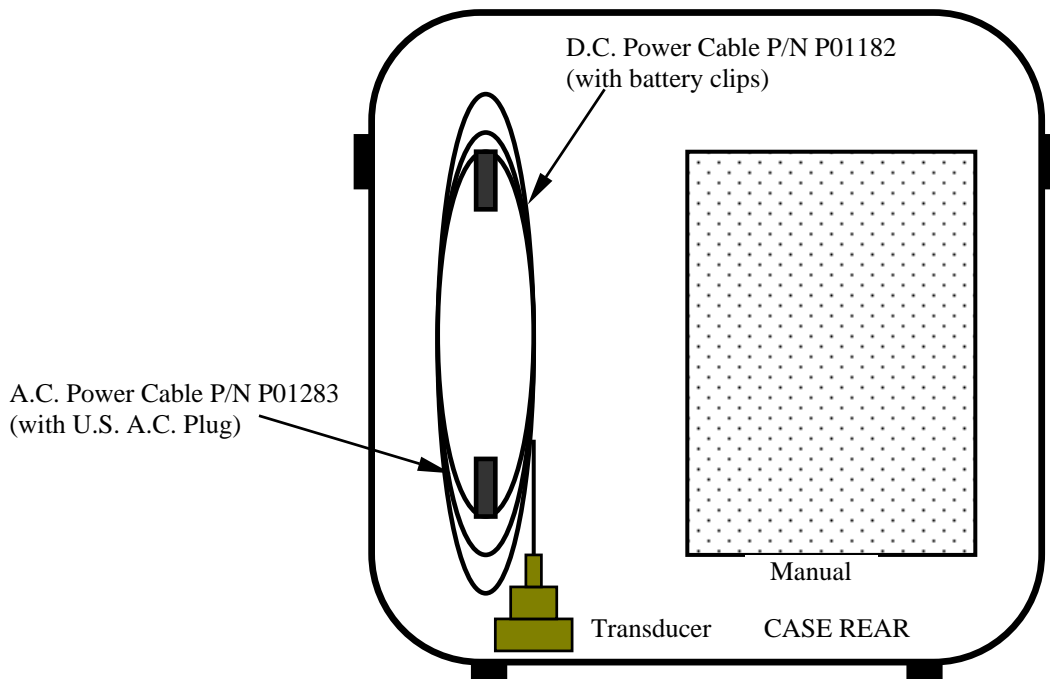

CHART MODULE - UNDERSIDE VIEW



P/N P01256 (CPU to Data I/O Cable)

CHART MODULE REAR (LOCATION OF DATA I/O PCB)



SYQWEST INCORPORATED

<http://www.syqwestinc.com>

[tech-support@syqwestinc.com](mailto:tech-support@syqwestinc.com)

**4.7 SPARE PARTS**

<u>SYQWEST Part Number</u>	<u>Description</u>
P01000	Thermal Printhead
P01001	Handle (carrying)
P01003	Gasket, Door
P01005	Catch
P01550	Gasket, Case
P01031	Rubber Bumper
P01034	Printhead Roller
P01042	Door Window
P01044	Data I/O Plug (complete kit)
P01050	Key/Display PCB
P01060	Print/Drive PCB
P01600	CPU PCB
P01080	Power Supply
P01090	Data I/O PCB
P01100	T/R PCB
P01181	Step Motor
P01182	D.C. Power Cable Assy. (with battery dips)
P01183	A.C. Power Cable Assy (with U.S. plug)
P01184	D.C. Fuse
P01185	A.C. Fuse
P01615	Membrane Decal (for keypad)
P01190	Keypad
P01192	Paper Loading Door
P01528	Window for LCD display
P01194	Paper Shaft
P01195	Paper Sensor PCB
P01196	Take-up End Internal Clutch
P01197	Supply End Internal Clutch
P01198	Supply End External Clutch
P01199	Take-up End Internal Clutch
P01200	Chart Paper Roll Kit (with take-up roll)
P01221	Print Head Lift Arm
P01234	P. Head-A Cable to Print/Drive PCB
P01235	P. Head-B Cable to Print/Drive PCB
P01251	Flex-Cable (Keypad to Key/Display PCB)
P01252	Ribbon Cable, P.S. PCB to CPU PCB
P01253	Ribbon Cable, T/R PCB to CPU PCB
P01254	Ribbon Cable, Print/Drive PCB to CPU PCB
P01255	Ribbon Cable, Key/Display PCB to CPU PCB
P01256	Ribbon Cable, Data I/O to CPU PCB
P01259	Ribbon Cable, Data I/O Chassis to Data I/O PCB
P01271	A.C. Power Chassis Harness Assy
P01272	D.C. Power Chassis Harness Assy
P01273	Transducer Chassis Harness Assy
P01274	FIX Mark Chassis Harness Assy
P01275	Paper Sensor Harness Assy
P01393	Print Head Tension Spring
P01394	Paper Loading Door Spring
P01395	Belt, Print Head Roller Pulley
P01396	Belt, Paper Supply Shaft Pulley

SYQWEST INCORPORATED

<http://www.syqwestinc.com>[tech-support@syqwestinc.com](mailto:tech-support@syqwestinc.com)

P01397	Belt, Paper Take-up Pulley
P01401	H.V. Protective Cover
P01475	Lamp PCB
P01477	Lamp
P01609	PC Port Chassis Harness Assy.
P01526	Bezel for Decal/Keypad
P01533	Backlight Keypad PCB

Note: See APPENDIX E for a listing of part numbers and descriptions of memory modules (software housed or microchips).

**APPENDIX A. - SPEED OF SOUND**

(as a function of salinity &amp; temperature)

**SV Table**

TEMP \ SAL	0 ppt.	5 ppt.	10 ppt.	15 ppt.	20 ppt.	25 ppt.	30 ppt.	35 ppt.	40 ppt.
0 deg. C	1400	1407	1414	1421	1481	1435	1442	1449	1445
5 deg. C	1424	1431	1437	1444	1451	1457	1464	1470	1447
10 deg. C	1445	1452	1458	1464	1471	1477	1483	1490	1496
15 deg. C	1464	1470	1476	1482	1488	1495	1501	1507	1513
20 deg. C	1481	1487	1493	1498	1504	1510	1516	1521	1527
25 deg. C	1496	1502	1507	1513	1518	1523	1529	1534	11540
30 deg. C	1510	1515	1520	1525	1530	1535	1540	1546	1551
35 deg. C	1522	1526	1531	1536	1541	1546	1551	1555	1560
40 deg. C	1532	1537	1541	1546	1551	1555	1560	1564	1569

*(Speed of Sound values are in meters per second)*

*THIS PAGE INTENTIONALLY LEFT BLANK*

**SYQWEST INCORPORATED**

<http://www.syqwestinc.com>

[tech-support@syqwestinc.com](mailto:tech-support@syqwestinc.com)



**APPENDIX B. - SELF TEST FEATURE**

Your Bathy-500MF contains an automatic self-test, which is initiated each time the unit is turned on. The display shown below generally indicates a properly functioning Bathy-500MF. Upon normal self-test (no errors found), this display screen will automatically clear itself.

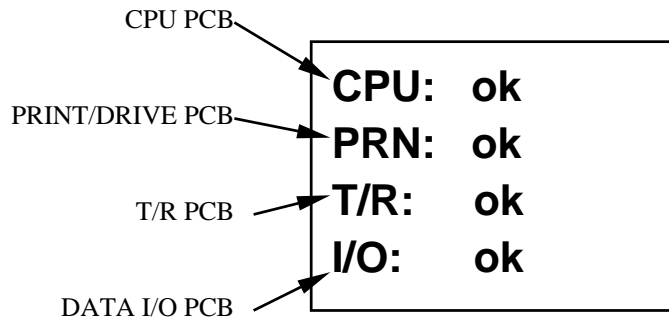

As shown above, the designation "ok" next to the PCB designation indicates normal (proper) functioning of that specific PCB. Should the self-test routine detect an error, the self test will halt after the last operational PCB is tested; The procedure will not continue until the first PCB found to have a problem is replaced. Then upon power-up again, the procedure will continue. For example, the display shown below indicates proper operation of the CPU and Print/Drive PCB's but a failure with the T/R PCB. The Data I/O PCB cannot thus be tested until the T/R PCB is replaced.

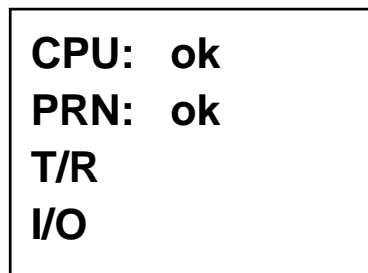

*THIS PAGE INTENTIONALLY LEFT BLANK*

**SYQWEST INCORPORATED**

<http://www.syqwestinc.com>

[tech-support@syqwestinc.com](mailto:tech-support@syqwestinc.com)

**APPENDIX C. - LIST OF STORED PARAMETERS**

When power is turned off to your Bathy-500MF, the following parameter values will be stored in memory; Upon re-application of power, these values will reappear and thus be used unless changed by the user.

- Gain Mode & Value (TVG Value)
- Units: (Feet or Meters)
- Range
- CAL (Speed of Sound)
- Paper Remaining (% of roll unused)
- Chart Print Contrast
- Chart Print Status: (On or Off)
- COM Format (Output Type)
- Display Mode: (Status Display Page or Depth Readout Page)

*THIS PAGE INTENTIONALLY LEFT BLANK*

**SYQWEST INCORPORATED**

<http://www.syqwestinc.com>

[tech-support@syqwestinc.com](mailto:tech-support@syqwestinc.com)

**APPENDIX D.    - Operation in Extremely Shallow Water Depths**

When operating in extremely shallow depths (less than one meter below the transducer), the minimum depth performance of your Bathy-500MF is primarily determined by the transmit pulse "ringing" of your specific transducer. For those users who primarily operate in minimum depths, it may be desirable to reduce the acoustic power of the instrument; This will reduce the "ringing" and thus result in a shallower minimum operating depth. It will also help reduce multiple bottom echoes typical of higher power units operating in very shallow water.

In the figure below, a portion of the T/R PCB (P/N P01100) is shown. Note that there are three jumper (link) positions; See arrows. Your Bathy-500MF is delivered with the jumper in link position "LK2"; This provides the maximum rated acoustic power output. Moving this jumper to "LK3" will reduce the output power, thus reducing transducer ringing, yet still providing adequate power for most depth applications.

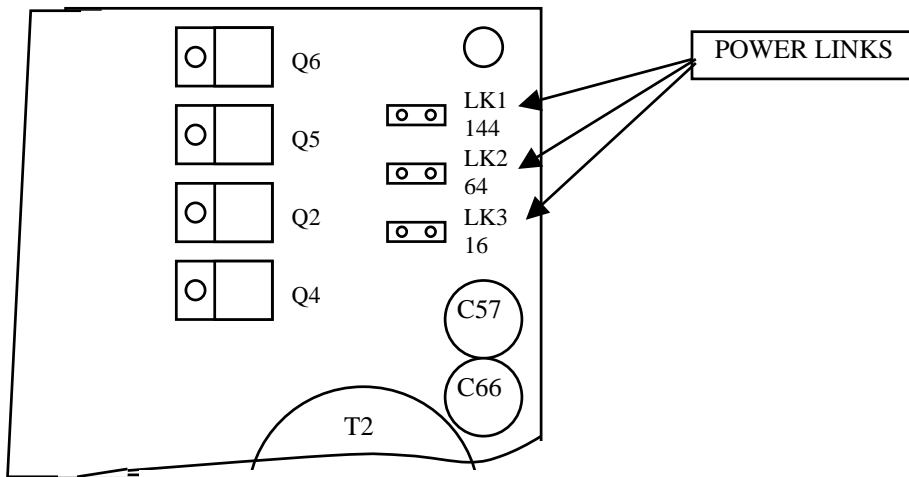

With regard to keypad setup, the user should turn the "GATE" off and first try very shallow water operation with "AUTOGAIN" ; If needed, the user may switch to "MANUAL" gain and adjust the "GAIN" and "TVG" for optimum shallow water operation.

*THIS PAGE INTENTIONALLY LEFT BLANK*

**SYQWEST INCORPORATED**

<http://www.syqwestinc.com>

[tech-support@syqwestinc.com](mailto:tech-support@syqwestinc.com)

**APPENDIX E. - Software**

Bathy-500MF Serial No. \_\_\_\_\_

Your Bathy-500MF contains a neural network of six RISC-based microprocessors, operating in parallel. The operating software is distributed throughout the network (on various PCB's) as each microprocessor contains internal memory (ROM). These six memory sites are located on the below listed PCB's.'

- P/N P01060 Print/Drive PCB
- P/N P01600 CPU PCB
- PIN P01100 T/R PCB
- P/N P01090 Data I/O PCB

All Bathy-500MF units have identical printed circuit board hardware; Only the microchips containing memory may differ between various version (upgrades) Bathy-500MF units. Accordingly, the above shown numbers for hardware (PCB's) apply to all Bathy-500MF units.

Data contained in the following pages provides the user with specifics of the software (firmware) configuration for your particular Bathy-500MF. Such information serves to allow the user or service station to verify the proper combination of firmware modules in a specified equipment serial number. SYQWEST part numbers needed to order particular firmware modules (microchips) are given in the attached pages, adjacent to the map of each PCB showing the memory site.

All firmware is contained on sockets as to provide for easy removal and/or installation on the PCB's. Firmware memory microchips are coded via firmware number; i.e. P0#### and by color code near pin one of the microchip. When installing firmware, particular care must be exercised as to insure that the microchip is properly oriented ("plugged-into") in the socket.

**SYQWEST INCORPORATED**<http://www.syqwestinc.com>[tech-support@syqwestinc.com](mailto:tech-support@syqwestinc.com)

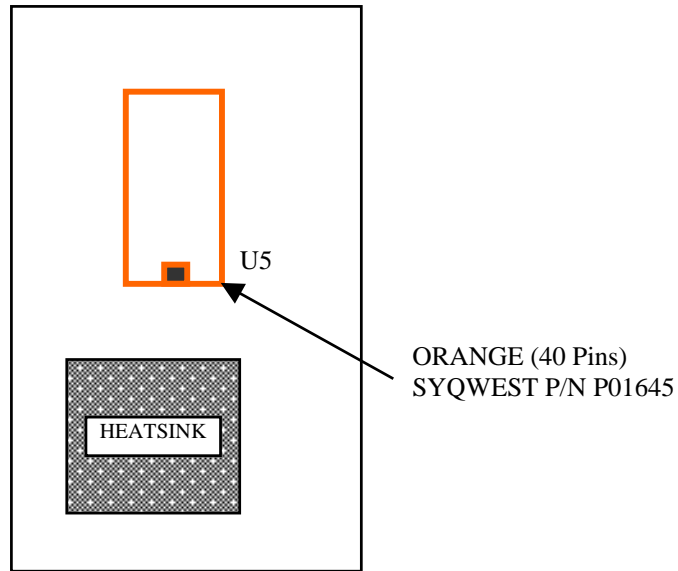

Part Number P01060 PRINT/DRIVE PCB

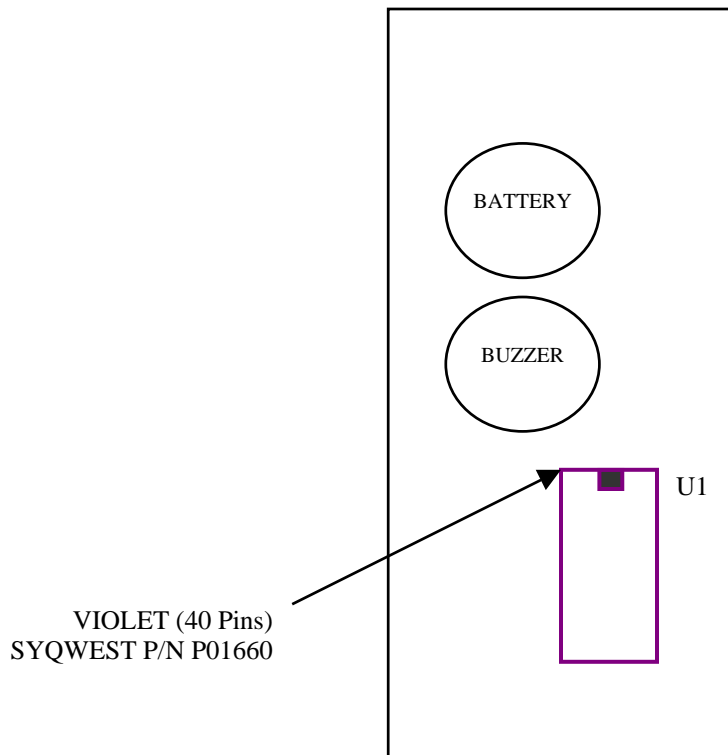

Part Number P01600 CPU PCB



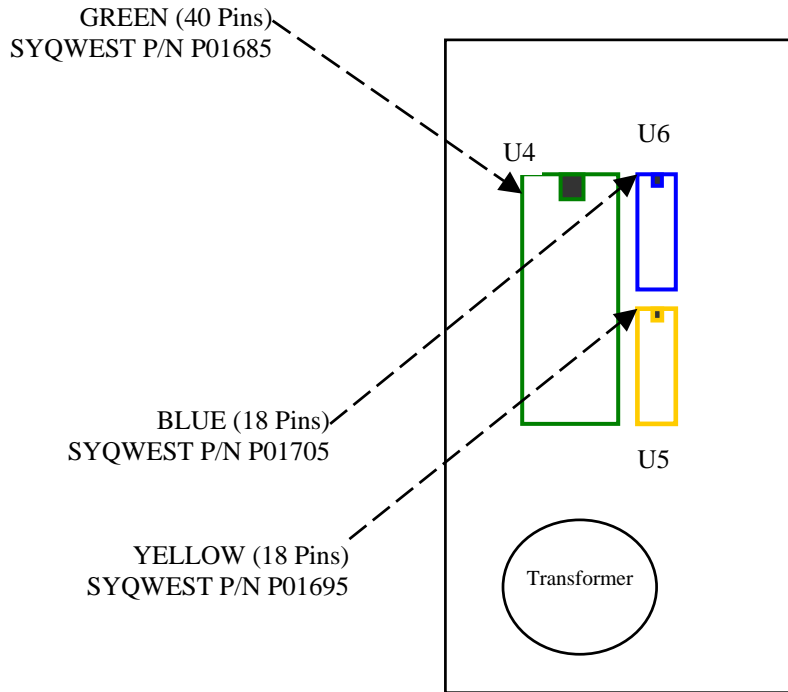

Part Number P01100 BROAD BAND T/R PCB

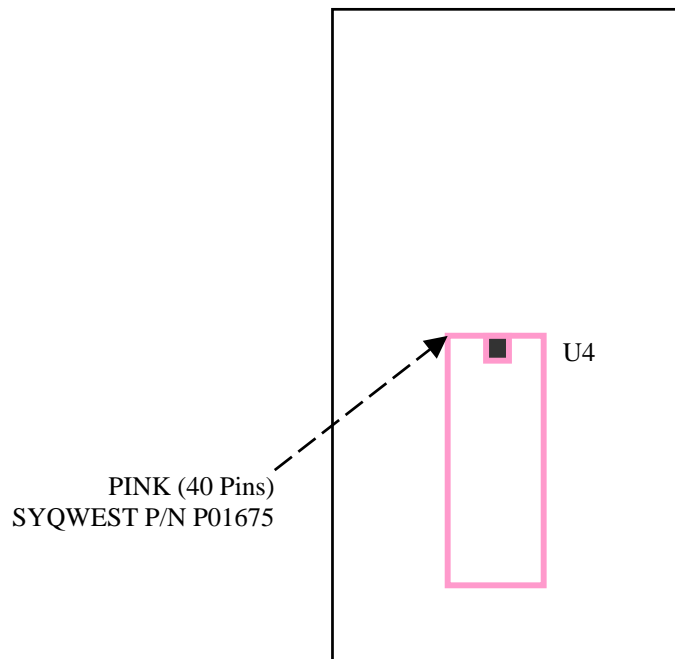

Part Number P01090 DATA I/O PCB

END